

KP27F Series

0.5mm Pitch, 21mm Stacking Height, 125°C Heat Resistant, Floating Board-to-Board Connector



High Temp



Floating



Automotive

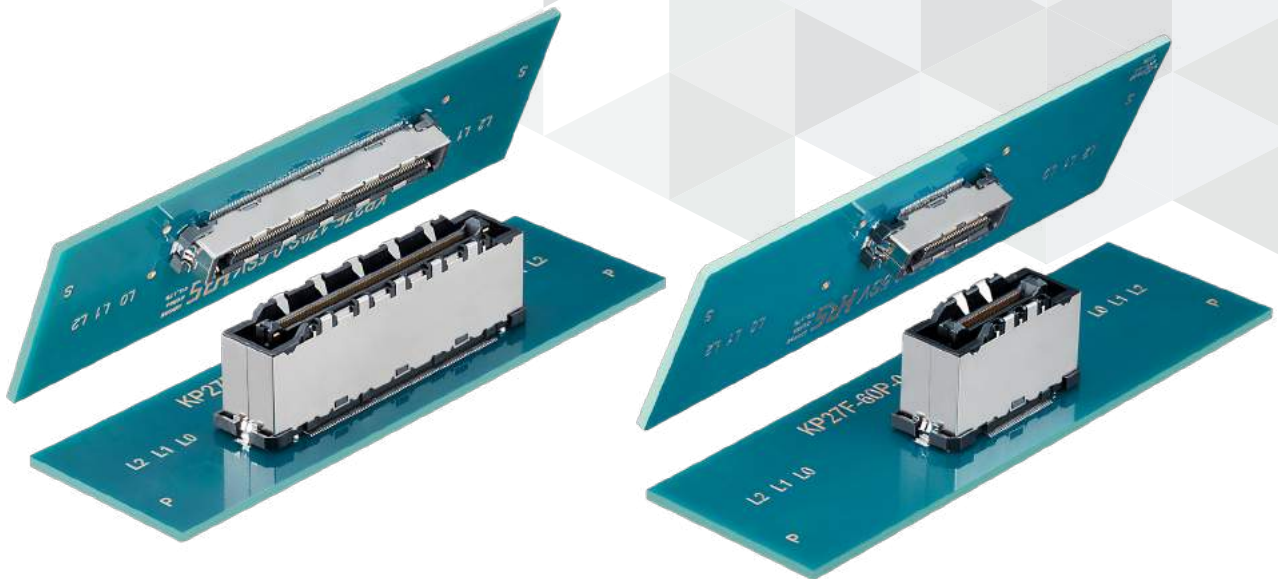

Product Page
<https://www.hirose.com/en/product/series/KP27F>

Features

1. Wide $\pm 0.8\text{mm}$ floating range in the X and Y directions

The floating part on the header side moves to absorb misalignment. This design allows multiple connectors to be mounted on a single board.

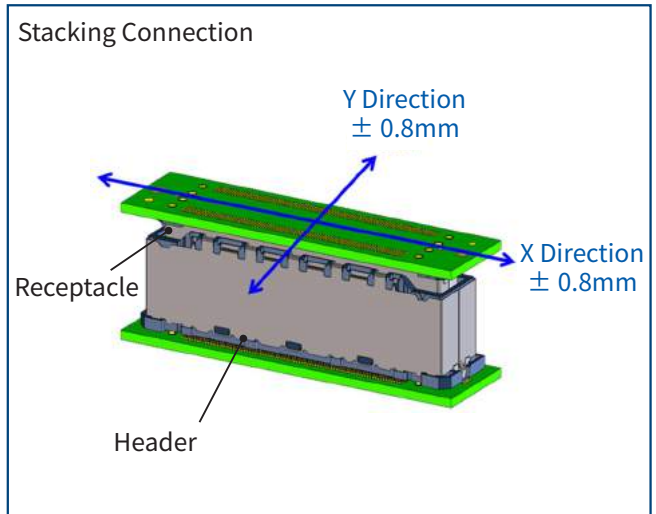

Floating Design

2. High speed transmission (8Gbps)

3. Shield and grounding provide EMI protection

Reliable grounding by connecting the Shield with retention tab.

*e. g. 170pos. : Contact sequence during mating is : shield, power supply contact, then signal contact.

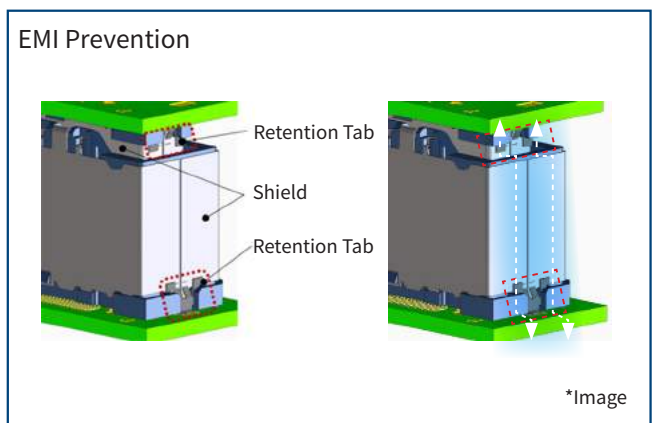

Shield Grounding Design

4. Wide self-alignment range : $\pm 1.2\text{mm}$ in X and Y directions

The self-alignment guide posts on both ends of the connector ensure easy and smooth mating.

5. Power contacts on each side of the connector (3A/Contact \times 4 Contacts)*

The power contacts on the guide posts are space-efficient and support up to 12A.

*Only 170pos. are available with power contacts. 60pos. may be considered upon request.

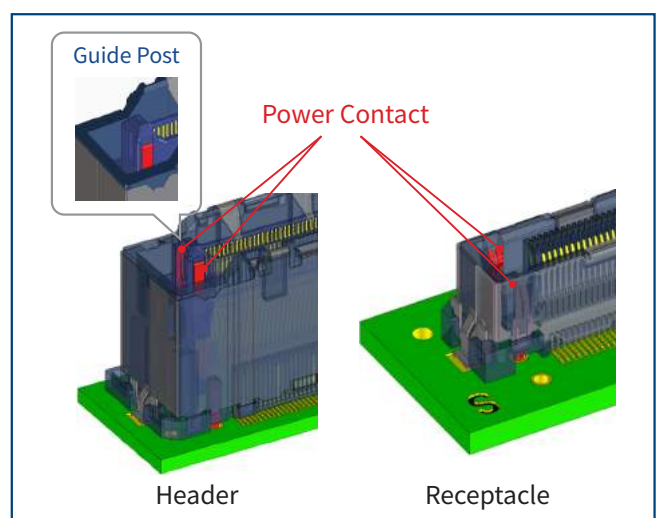

Hybrid Power & Signal Design with Large Guide Posts on Both Ends

Product Specifications

Rated Current (Note 1)	Signal	Power (Note 2)	Operating Temperature (Note 3)	-55 to +125°C
	0.5A	3.0A	Operating Humidity Range (Note 4)	Relative Humidity 85% Max.
Rated Voltage	Signal	Power (Note 2)	Storage Temperature (Note 5)	-10 to +60°C
	50V AC	200V AC	Storage Humidity Range (Note 4)(Note 5)	Relative Humidity 85% Max.

Items	Specifications	Conditions
Contact Resistance	Signal Contact : 50mΩ Max. Power Contact : 30mΩ Max.	Measured at 100mA
Insulation Resistance	Signal Contact : 100MΩ Min. Power Contact : 1000MΩ Min.	Measured at Signal Contact : 100V DC Power Contact : 250V DC
Withstanding Voltage	No insulation breakdown.	150V AC for 1 min.
Mating Durability	Contact Resistance : Signal Contact : 70mΩ Max. Power Contact : 40mΩ Max.	100 times
Vibration Resistance	No electrical discontinuity of 1μs or more	Frequency 10 to 55Hz, half amplitude 0.75mm, 10 cycles in each of the 3-axis directions each for 5 minutes per cycle
Shock Resistance	No electrical discontinuity of 1μs or more	Acceleration of 490m/s ² , 11ms duration, 3times for 3 both axial directions
Humidity Resistance	Contact Resistance : Signal Contact : 70mΩ Max. Power Contact : 40mΩ Max. Insulation Resistance : Signal Contact : 100MΩ Min. Power Contact : 1000MΩ Min.	Left for 96 hours at temperature of 40°C and humidity range from 90 to 95%
Temperature Cycle	Contact Resistance : Signal Contact : 70mΩ Max. Power Contact : 40mΩ Max. Insulation Resistance : Signal Contact : 100MΩ Min. Power Contact : 1000MΩ Min.	Temperature : -55 → +125°C Time : 30 → 30 minutes for 5 cycles (Relocation time to chamber : within 2 to 3 minutes)

Note 1 : When passing the current through all of the contacts, use 70% of the current rating.

Note 2 : Only 170pos. are available with power contacts. 60pos. may be considered upon request.

Note 3 : Includes the temperature rise due to current flow.

Note 4 : Use without condensation.

Note 5 : Storage refers to the long-term storage condition of unused products prior to PCB mounting.

The operating temperature and humidity range are applicable to the non-energized state after PCB mounting.

Materials / Finish

Product	Component	Materials	Color / Finish	UL Standard
Header Receptacle	Insulator	LCP (Note 1)	Black	UL94V-0
	Shield	Copper Alloy	Nickel Plated	-
	Signal Contact	Copper Alloy	Contact Area / Lead Area : Gold Plated over Nickel Underplating	-
	Power Contact (Note 2)	Copper Alloy	Contact Area/Lead Area : Gold Plated over Nickel Underplating	-
	Retention Tab	Copper Alloy	Tin Plated over Nickel Underplating	-

Note 1 : This product satisfies halogen free requirements defined as 900ppm maximum chlorine,900ppm maximum bromine, and 1500ppm maximum total of chlorine and bromine.
 Note 2 : Only 170pos. are available with power contacts. 60pos. may be considered upon request.

Product Number Structure

Refer to the chart below when determining the product specifications from the product number.
 Please select from the product numbers listed in this catalog when placing orders.

Header / Receptacle

KP27F - **170** **P / 4** - **0.5** **SV** **21** **(800)**
 ① ② ③ ④ ⑤ ⑥ ⑦ ⑧

① Series Name	KP27F	⑤ Contact Pitch	0.5mm
② No. of Pos. : Signal Contact	60, 170pos.	⑥ Product Type	SV : SMT Straight Mounting Type
③ Connector Type	P : Header S : Receptacle	⑦ Stacking Height	21mm
④ No. of Pos. : Power Contact (Note)	Blank : None 4 : 4pos.	⑧ Specification	Tray Packaging, Compatible with Molded Caps

Note : Only 170pos. are available with power contacts. 60pos. may be considered upon request.

High Speed Transmission (KP27F : h=21mm)

● Pin Assignment

The following pin arrangement is recommended to match the 100Ω differential impedance and to contain cross-talk.

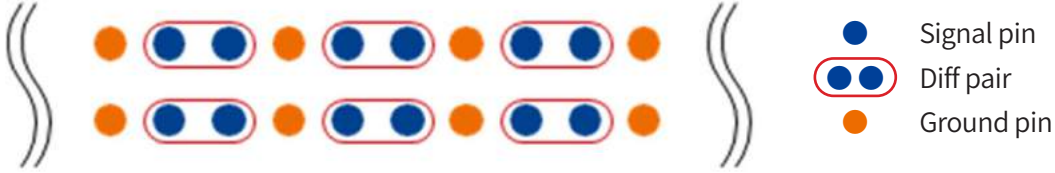

● Differential Impedance 87.5ps Rise Time (20 to 80%)

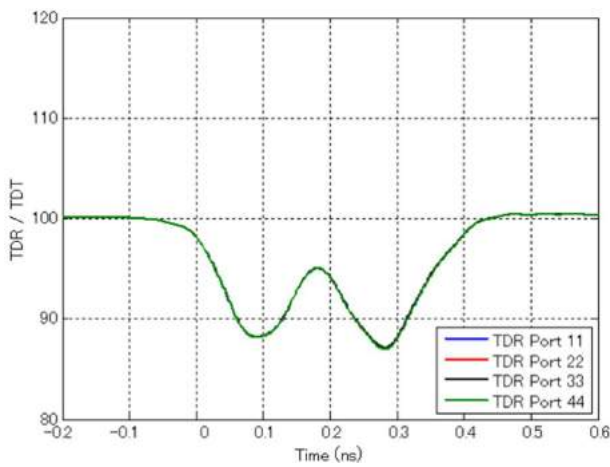

Meets the criterion of $100 \pm 15\Omega$ at the rise time of 87.5ps (20 to 80%).

● Insertion Loss

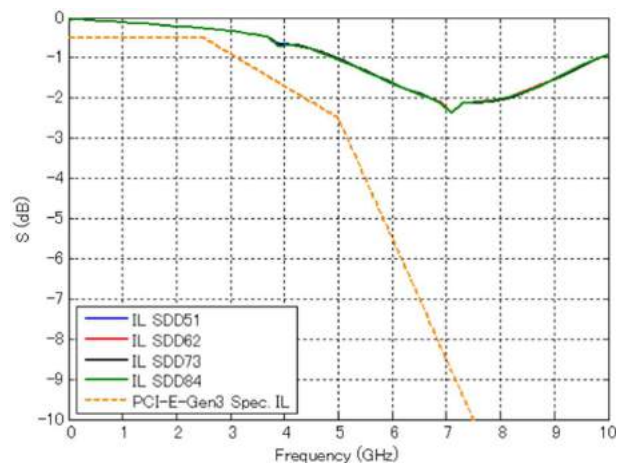

● Return Loss

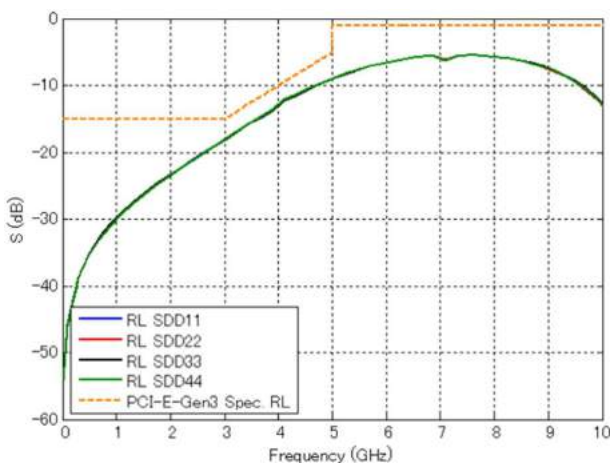

● Near End Cross-Talk (NEXT)

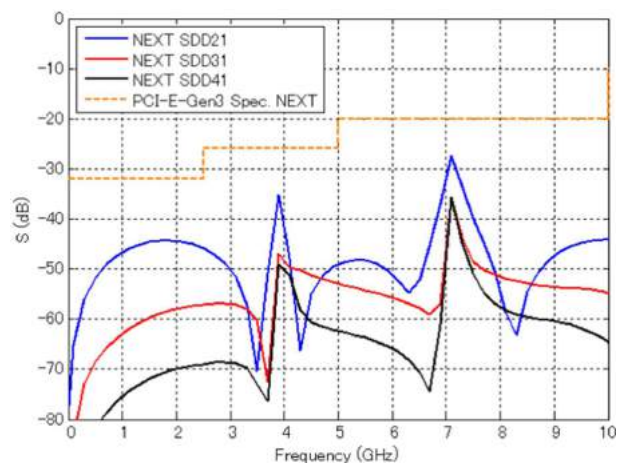

60pos. Receptacle

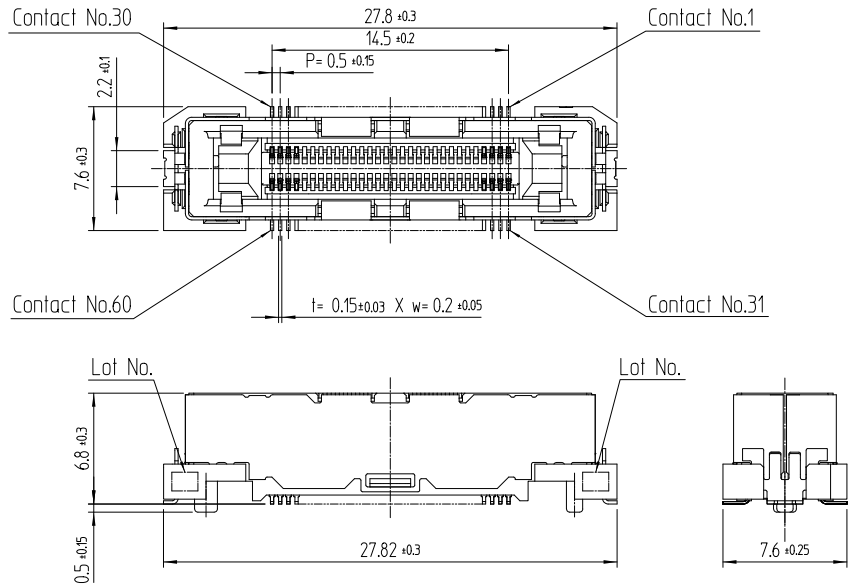
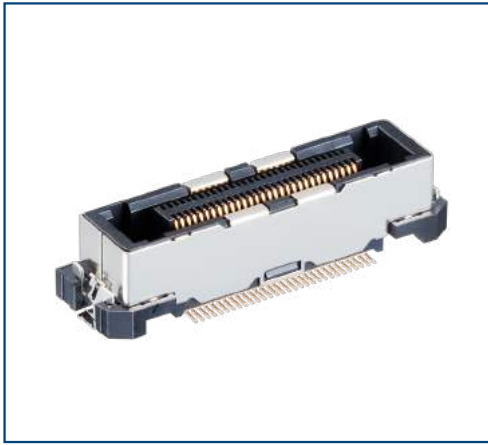

Recommended Land Pattern
(PCB Thickness : t=1.6mm)

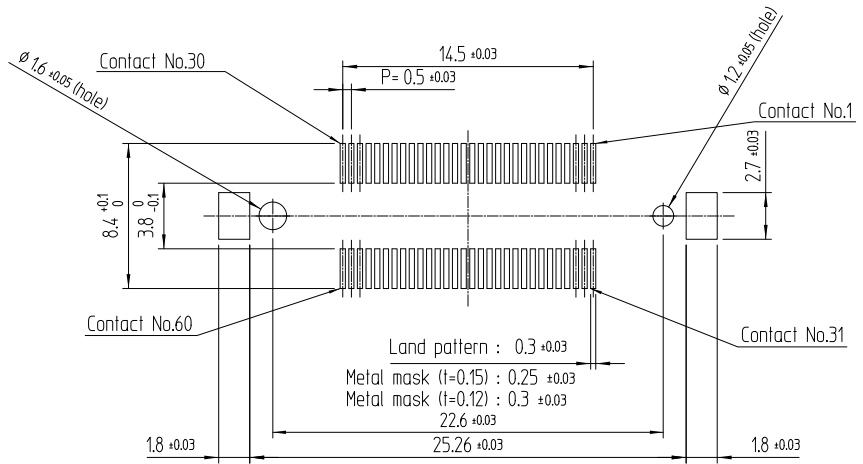

Part No.	HRS No.	No. of Pos.		Purchase Unit
		Signal Contact	Power Contact	
KP27F-60S-0.5SV(800)	CL0480-0781-0-00	60	-	750pcs per tray

Note : Only 170pos. are available with power contacts. 60pos. may be considered upon request.

170pos. Header

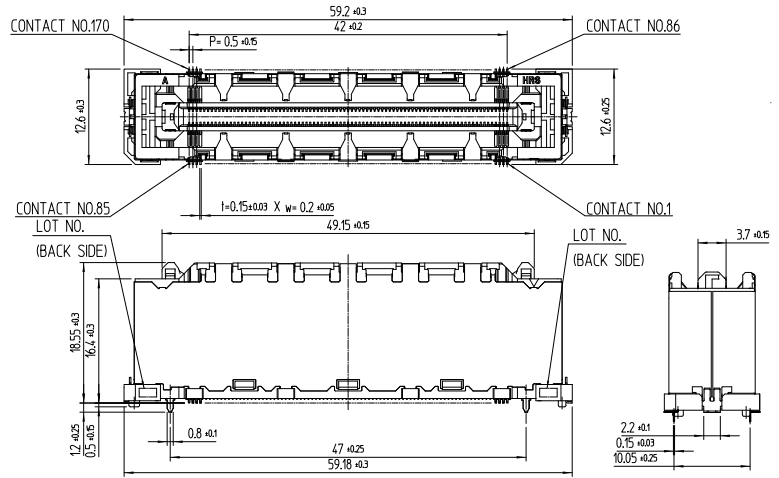

Recommended Land Pattern
(PCB Thickness : t=1.6mm)

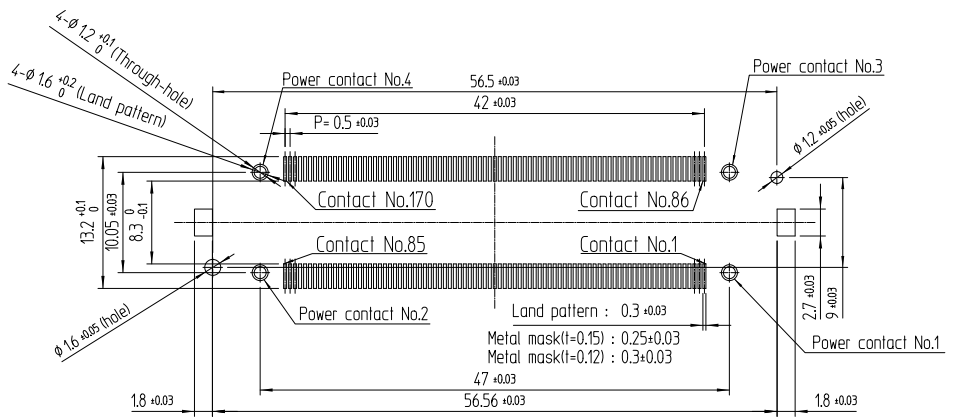

Part No.	HRS No.	No. of Pos.		Purchase Unit
		Signal Contact	Power Contact	
KP27F-170P/4-0.5SV21(800)	CL0480-0782-0-00	170	4	240pcs per tray

Tray Packaging Specifications

*Compatible with molded caps. Please remove the suction cap after mounting.

60pos. Header : KP27F-60P-0.5SV21(800)

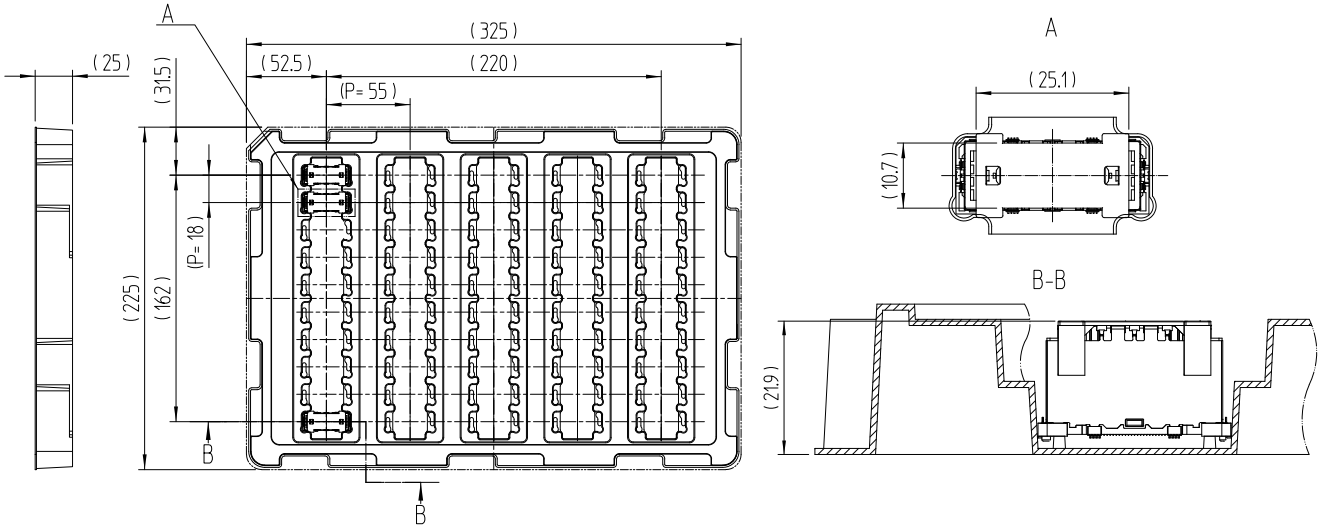

60pos. Receptacle : KP27F-60S-0.5SV(800)

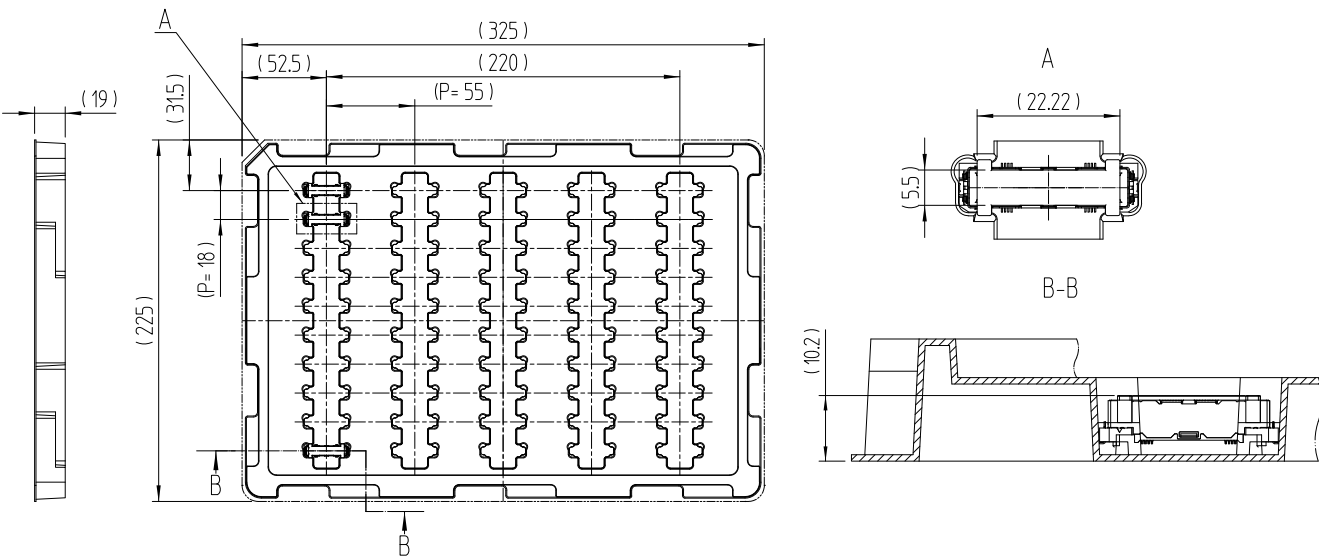

*Compatible with molded caps. Please remove the suction cap after mounting.

170pos. Header : KP27F-170P/4-0.5SV21(800)

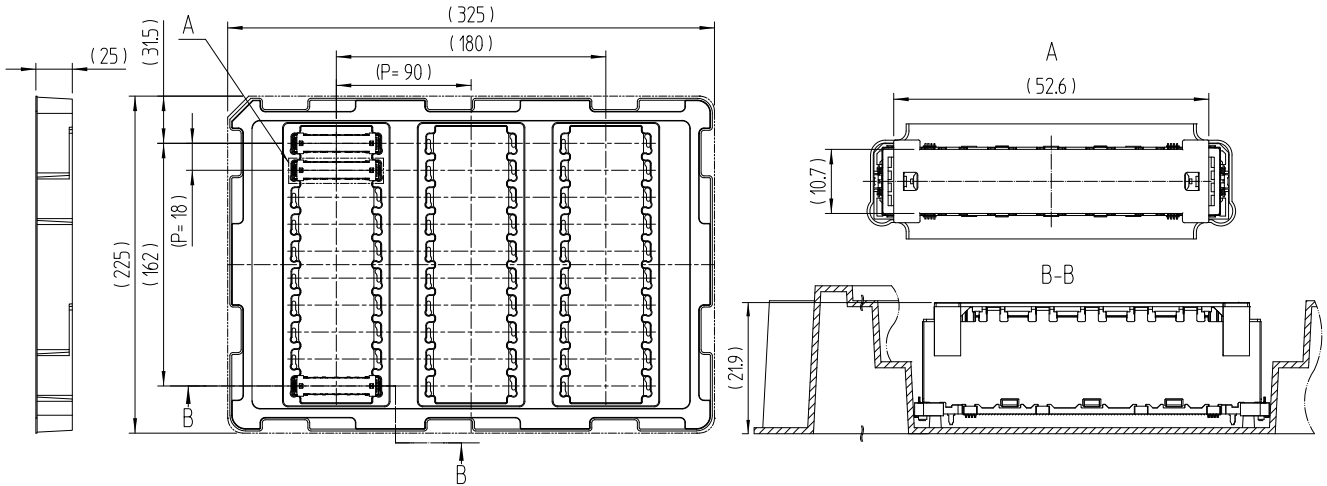

170pos. Receptacle : KP27F-170S/4-0.5SV(800)

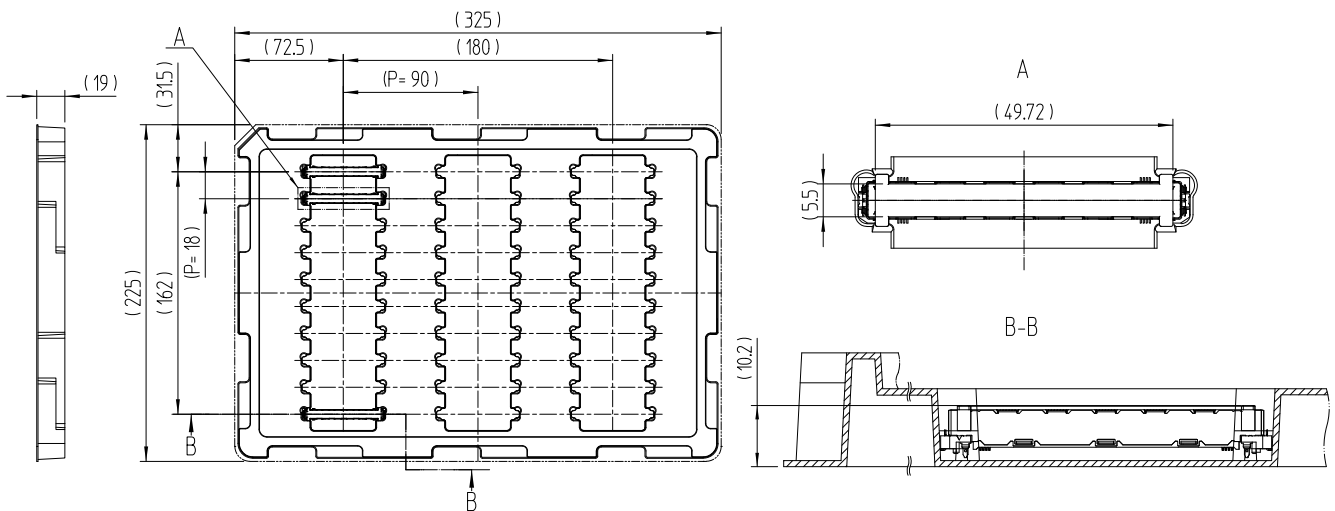

Storing KP27F Series

There are two types of trays (A and B) for the KP27F Series. These have been designed to stack in alternating order (A-B-A-B. . .) for shipping and storage.

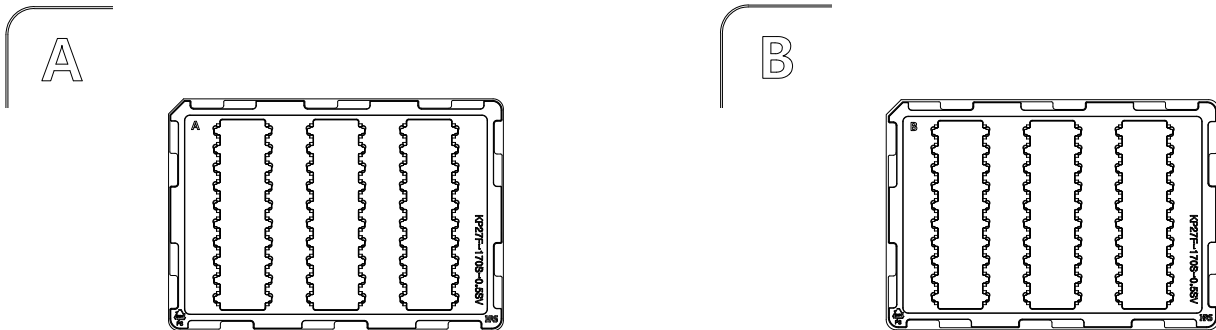

If tray A is stacked on top of another tray A, or if tray B is stacked on top of another tray B, the trays will put a load on the connectors, potentially causing connector breakage or deformation.



When stacked correctly, the outer structure of the trays will prevent any load from being placed on the connectors below.

When stacked incorrectly, the outer structure of the trays will not function, resulting in a load added to the connector.

When storing the KP27F Series, please ensure that the trays are stacked in alternating order.

Recommended Temperature Profile

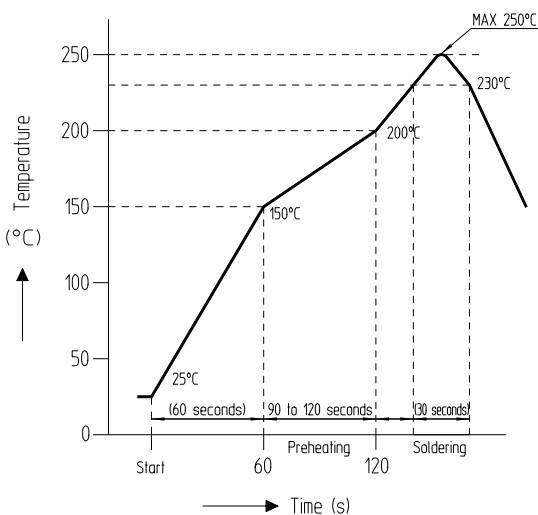

<Applicable Conditions>

Material	: Glass epoxy
Solder Composition	: Sn-3Ag-0.5Cu
Flux Content	: 11wt%
Metal Mask Thickness	: 0.12mm, 0.15mm
Number of Reflow Time	: 1 time Max.

*The temperature profile is for the above conditions. The temperature profile may vary depending on the type of cream solder, the manufacturer, the board size and other conditions such as mounting materials. Please check the mounting status before use.

Usage Precautions

● About the Specified Dimension Between PCBs

Use within the specified dimensions between PCBs below.

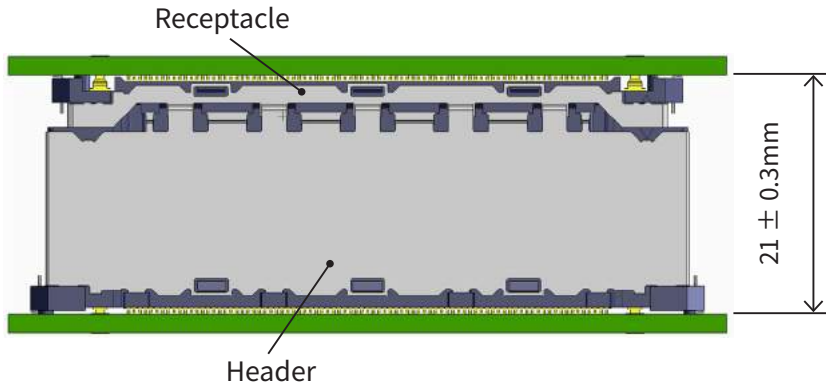

● Securing PCBs

Please take measures to secure the PCB other than using connectors. Using only the connectors to support the board may result in a load to the connector that results in damage or contact failure.

● Cautions in Mating Operations

This connector is designed to prevent reverse insertion. The connector could be damaged if excessive force is exerted when mating. Avoid excessive force when mating. Mate only after confirming the following connector properties. (chamfer of the external face).

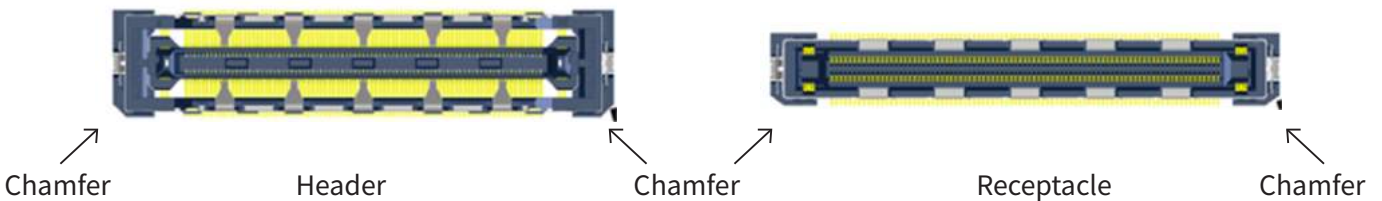

The self-alignment range is $\pm 1.2\text{mm}$ in both the X and Y directions. After beginning to mate the connectors within the misalignment range, proceed by mating in a straight line without forcing the connector.

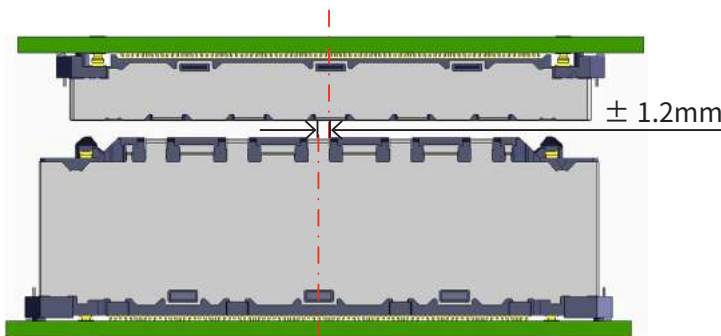

X Direction (Longitudinal Direction)

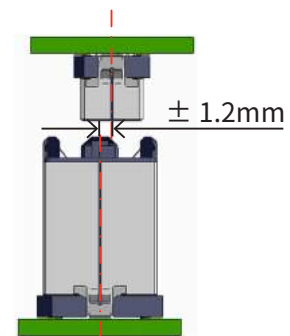

Y Direction (Transverse Direction)

Note : If misalignment axis is inevitable in all directions from the beginning to the end of the mating operation, please use within the tolerable range. ($\pm 0.8\text{mm}$ in both the X and Y directions.)

When mating/un-mating, it is strongly recommended to insert or remove in a straight line.
 If not possible due to board layout, insertion and removal should be carried out within the following inclination angle.
 Moreover, during the mating operation, be sure to proceed without forcibly applying a load to the connector.
 Allow the connector to be placed straight when the mating operation is completed.

- X Direction (Longitudinal Direction) ⇒ for 60pos. : within 2°, for 170pos. : within 10°
- Y Direction (Transverse Direction) ⇒ within 0.5°

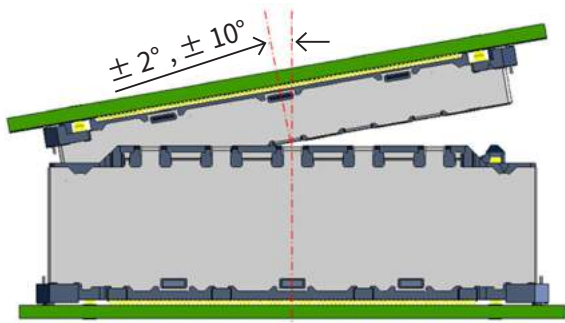

X Direction (Longitudinal Direction)

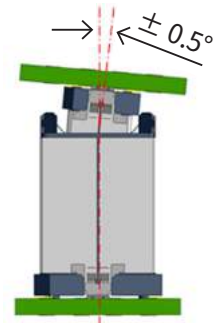

Y Direction (Transverse Direction)

Note : Rotating insert/extract operations are not recommended. Damage to the connector could occur.

● Permissible Misalignment in the Mated State (Floating Amount)

This connector is designed to float when mated.
 The permissible misalignment between PCBs in the mated state is ±0.8mm in both the X and Y directions.
 However, this connector is not suitable for misalignment absorption when the misalignment amount is constantly changing due to vibration, etc. Be sure to secure PCBs after mating.
 Additionally, the number of repetitive floating operations shall be according to the number of connector insertion/withdrawal cycles. (100 times Max.)

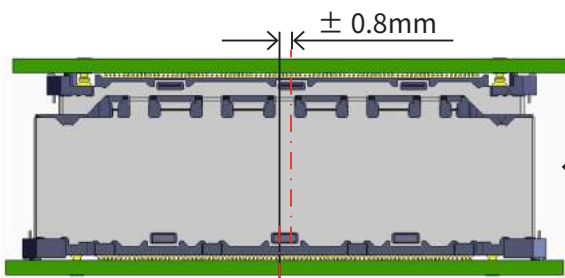

X Direction (Longitudinal Direction)

← Floating Side →

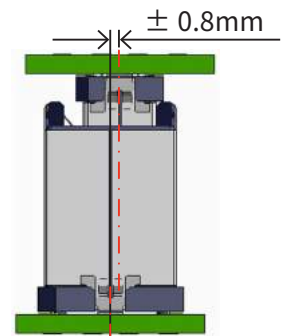

Y Direction (Transverse Direction)

While Taking into Consideration

- Specifications mentioned in this catalog are reference values.
- When considering to order or use this product, please review the Drawing and Product Specifications sheets.
- Use an appropriate cable when using the connector in combination with cables.
- If considering usage of a non- specified cable, please contact your sales representative.
- If assembly process is done by jigs & tools which are not identified by Hirose, the warranty of the product may be affected.
- If considering usage for below mentioned applications, please contact your sales representative.
- In cases where the application will demand a high level of reliability, such as automotive, medical instruments, public infrastructure, aerospace/ defense etc. Hirose must review before assurance of reliability can be given.