

Typical unit

## FEATURES

- 51W DC-DC converter with supporting IEEE802.3bt class6 (MYBSP0124CAZFT)
- 72W DC-DC converter with supporting IEEE802.3bt class8 (MYBSP01206AZFT)
- Support PSE Type Indicators
- Support Adapter ORing
- 41.1-57V Input Voltage range
- 22.2 x 56.4 x 8.6mm Size
- 92.8% efficiency (typical) (MYBSP0124CAZFT)
- 93.2% efficiency (typical) (MYBSP01206AZFT)
- 2250Vdc Input-Output Isolation
- Operating Temperature range -40 to +85 degC

## PRODUCT OVERVIEW

MYBSP0124CAZFT and MYBSP01206AZFT are isolated, regulated, DC-DC converters for PoE PD that have an input range of 41.1-57Vdc with a typical efficiency of 92.8% for MYBSP0124CAZFT and 93.2% for MYBSP01206AZFT and full 2250 Volt DC isolation.

MYBSP0124CAZFT and MYBSP01206AZFT are ideal for IEEE 802.3bt Compliant Devices. The modules have detection and classification for compliant IEEE802.3bt. MYBSP0124CAZFT and MYBSP01206AZFT have PSE Type Indicator function and Adapter ORing function.

The modules have self-protection features. These include input undervoltage lockout, output current limit, output overvoltage protection and overtemperature protection. The outputs current limit is using the hiccup auto restart technique.

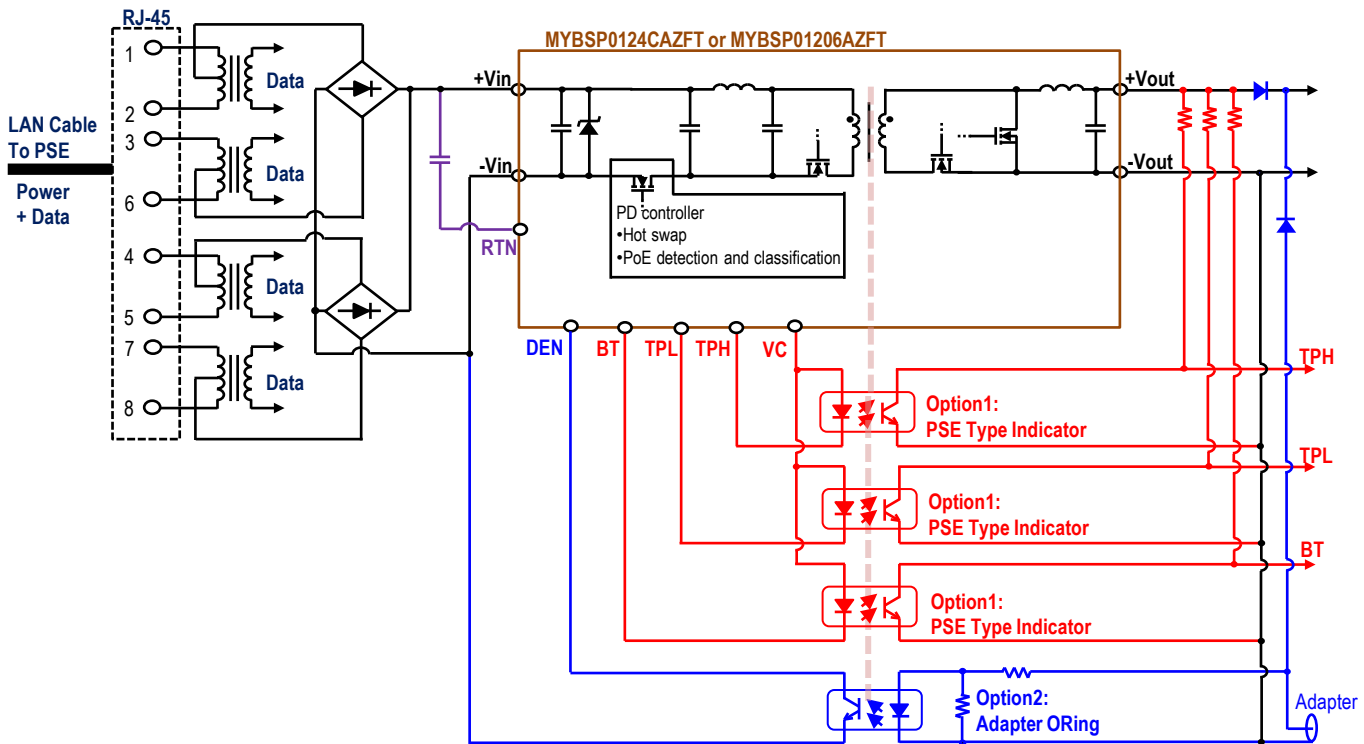

Typical topology is shown.

Figure 1. Simplified Block Diagram

**Table 1. Performance Specifications Summary and Ordering Information**

| PERFORMANCE SPECIFICATIONS SUMMARY AND ORDERING GUIDE |          |                 |           |                    |                   |          |                |           |                         |                          |        |              |                   |
|-------------------------------------------------------|----------|-----------------|-----------|--------------------|-------------------|----------|----------------|-----------|-------------------------|--------------------------|--------|--------------|-------------------|
| Model Number                                          | Output   |                 |           |                    |                   | Input    |                |           |                         | Efficiency [%]           |        | Package [mm] |                   |
|                                                       | Vout [V] | Iout [A] (Max.) | Power [W] | R/N [mVp-p] (Typ.) | Regulation (Typ.) |          | Vin [V] (Nom.) | Range [V] | Iin, no load [mA](Typ.) | Iin, full load [A](Typ.) | (Min.) |              | (Typ.)            |
|                                                       |          |                 |           |                    | Line [%]          | Load [%] |                |           |                         |                          |        |              |                   |
| MYBSP012CAZFT                                         | 12       | 4.25            | 51        | 100                | ±0.1              | ±0.1     | 48             | 41.1-57   | 44.7                    | 1.14                     | 90.5   | 92.8         | 22.2 x 56.4 x 8.6 |
| MYBSP01206AZFT                                        | 12       | 6               | 72        | 100                | ±0.1              | ±0.1     | 48             | 41.1-57   | 54.0                    | 1.61                     | 91     | 93.2         | 22.2 x 56.4 x 8.6 |

1. Please refer to the Part Number Structure for additional ordering information and options.
2. All specifications are at nominal line voltage, full load, +25degC unless otherwise stated.

**Table 2. Part Numbering**

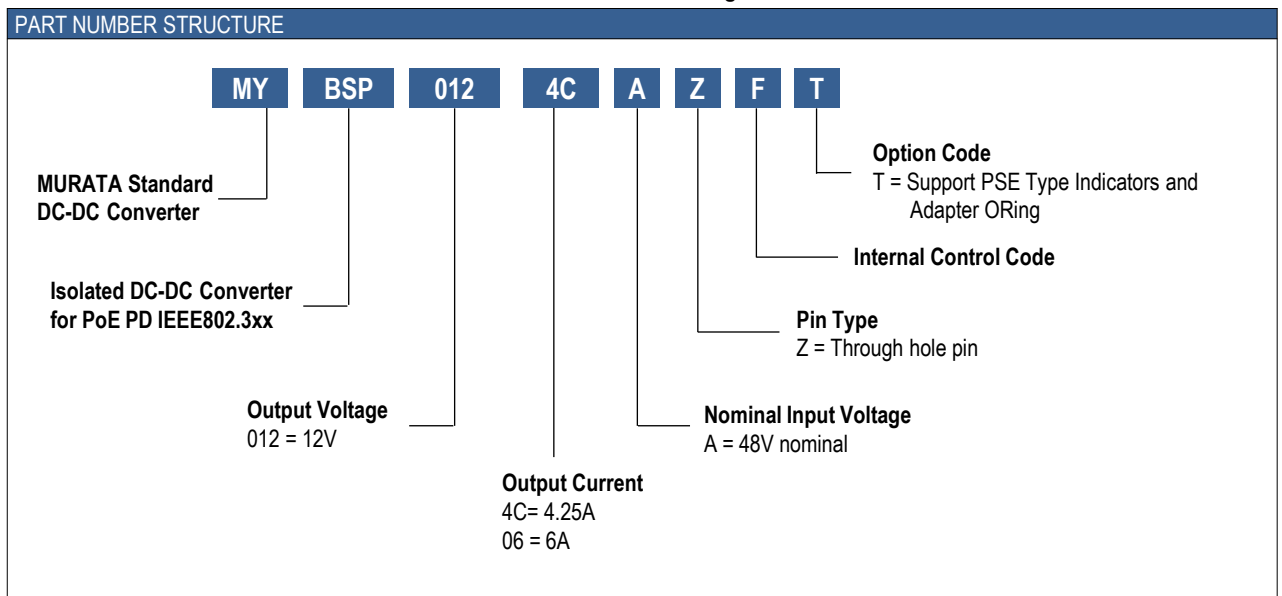

**Product Marking**

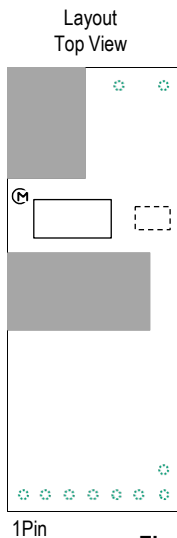

- Codes**
- Ⓜ Murata Manufacturing ID
  - Model Number
  - ⋯ Internal Manufacturing Code

| PART NUMBER    | MODEL NUMBER   |
|----------------|----------------|
| MYBSP012CAZFT  | MYBSP012CAZFT  |
| MYBSP01206AZFT | MYBSP01206AZFT |

**Figure 2. Top Marking Specification**

FUNCTIONAL SPECIFICATIONS, MYBSP0124CAZFT, MYBSP01206AZFT

**Table 3. Functional Specifications**

| ABSOLUTE MAXIMUM RATINGS                                                                                                                                                                                                                                                                  | Conditions                                                          | Minimum          | Typical / Nominal | Maximum | Units                   |
|-------------------------------------------------------------------------------------------------------------------------------------------------------------------------------------------------------------------------------------------------------------------------------------------|---------------------------------------------------------------------|------------------|-------------------|---------|-------------------------|
| Input Voltage, Continuous                                                                                                                                                                                                                                                                 |                                                                     | 0                |                   | 57      | Vdc                     |
| Input Voltage, Transient                                                                                                                                                                                                                                                                  | 100ms max. duration                                                 |                  |                   | 60      | Vdc                     |
| Isolation Voltage                                                                                                                                                                                                                                                                         | Input to output, Leak current 1mA max for 1minute at +25degC/60%RH. |                  |                   | 2250    | Vdc                     |
| Output Power                                                                                                                                                                                                                                                                              | MYBSP0124CAZFT                                                      | 0                |                   | 51      | W                       |
|                                                                                                                                                                                                                                                                                           | MYBSP01206AZFT*1                                                    | 0                |                   | 72      |                         |
| Output Current                                                                                                                                                                                                                                                                            | MYBSP0124CAZFT                                                      | 0                |                   | 4.25    | A                       |
|                                                                                                                                                                                                                                                                                           | MYBSP01206AZFT                                                      | 0                |                   | 6       |                         |
| Storage Temperature Range                                                                                                                                                                                                                                                                 | Vin = Zero (no power)                                               | -40              |                   | 90      | degC                    |
| Absolute maximums are stress ratings. Exposure of devices to greater than any of these conditions may adversely affect long-term reliability. Proper operation under conditions other than those listed in the Performance/Functional Specifications Table is not implied or recommended. |                                                                     |                  |                   |         |                         |
| <b>INPUT</b>                                                                                                                                                                                                                                                                              |                                                                     |                  |                   |         |                         |
| Operating Voltage Range                                                                                                                                                                                                                                                                   |                                                                     | 41.1             | 48                | 57      | Vdc                     |
| Start-up threshold                                                                                                                                                                                                                                                                        | Rising input voltage                                                | 36.1             |                   | 40.2    | Vdc                     |
| Under voltage shutdown                                                                                                                                                                                                                                                                    | Falling input voltage                                               | MYBSP0124CAZFT   |                   | 35.3    | Vdc                     |
|                                                                                                                                                                                                                                                                                           |                                                                     | MYBSP01206AZFT   | 30.3              | 33.8    |                         |
| Internal Filter Type                                                                                                                                                                                                                                                                      |                                                                     |                  | Pi                |         |                         |
| <b>Input current</b>                                                                                                                                                                                                                                                                      |                                                                     |                  |                   |         |                         |
| Full Load Conditions                                                                                                                                                                                                                                                                      | Vin = nom., Iout = max.                                             | MYBSP0124CAZFT   |                   | 1.14    | A                       |
|                                                                                                                                                                                                                                                                                           |                                                                     | MYBSP01206AZFT   |                   | 1.61    |                         |
| Low Line Input current                                                                                                                                                                                                                                                                    | Vin = min., Iout = max.                                             | MYBSP0124CAZFT   |                   | 1.35    | A                       |
|                                                                                                                                                                                                                                                                                           | Vin = min., Iout = 5.85A                                            | MYBSP01206AZFT*1 |                   | 1.85    |                         |
| No Load Current                                                                                                                                                                                                                                                                           | Vin = nom., Iout = 0A                                               | MYBSP0124CAZFT   |                   | 44.7    | mA                      |
|                                                                                                                                                                                                                                                                                           |                                                                     | MYBSP01206AZFT   |                   | 54.0    |                         |
| Current Limit Inception                                                                                                                                                                                                                                                                   | MYBSP0124CAZFT                                                      | 1.55             |                   |         | A                       |
|                                                                                                                                                                                                                                                                                           | MYBSP01206AZFT*1                                                    | 1.9              |                   |         |                         |
| On Resistance of Internal Hotswap                                                                                                                                                                                                                                                         | MYBSP0124CAZFT                                                      |                  | 0.3               |         | Ω                       |
|                                                                                                                                                                                                                                                                                           | MYBSP01206AZFT                                                      |                  | 0.1               |         |                         |
| Resistance for detection                                                                                                                                                                                                                                                                  | Vin=2.7 to 10.1V                                                    |                  | 24.9              |         | kΩ                      |
| Classification current A                                                                                                                                                                                                                                                                  | Vin=14.5 to 20.5V                                                   |                  | 39.9              |         | mA                      |
| Classification current B                                                                                                                                                                                                                                                                  | Same as above                                                       | MYBSP0124CAZFT   |                   | 10.6    | mA                      |
|                                                                                                                                                                                                                                                                                           |                                                                     | MYBSP01206AZFT   |                   | 27.9    |                         |
| Maximum Capacitive Loading                                                                                                                                                                                                                                                                | Added between positive input (+ Vin) and RTN                        | 0                |                   | 100     | uF                      |
| <b>GENERAL and SAFETY</b>                                                                                                                                                                                                                                                                 |                                                                     |                  |                   |         |                         |
| Efficiency                                                                                                                                                                                                                                                                                | Vin = 48V, full load                                                | MYBSP0124CAZFT   | 90.5              | 92.8    | %                       |
|                                                                                                                                                                                                                                                                                           |                                                                     | MYBSP01206AZFT   | 91                | 93.2    |                         |
| <b>Isolation</b>                                                                                                                                                                                                                                                                          |                                                                     |                  |                   |         |                         |
| Isolation Voltage                                                                                                                                                                                                                                                                         | Input to output, Leak current 1mA max for 1minute at +25degC/60%RH. | 2250             |                   |         | Vdc                     |
| Insulation Safety Rating                                                                                                                                                                                                                                                                  |                                                                     |                  | Functional        |         |                         |
| Isolation Capacitance                                                                                                                                                                                                                                                                     |                                                                     |                  | 1500              |         | pF                      |
| Calculated MTBF                                                                                                                                                                                                                                                                           | Telcordia SR-332, issue 1, class 3, ground fixed, Ta = +25degC      |                  | 1265              |         | Hours x 10 <sup>3</sup> |
| <b>DYNAMIC CHARACTERISTIC</b>                                                                                                                                                                                                                                                             |                                                                     |                  |                   |         |                         |
| Fixed Switching Frequency                                                                                                                                                                                                                                                                 |                                                                     |                  | 410               |         | kHz                     |
| Vout Rise Time                                                                                                                                                                                                                                                                            | From 10%-90% of Vout                                                |                  | 1                 |         | ms                      |
| Dynamic Load Response                                                                                                                                                                                                                                                                     | 50-100-50% load step to 1% of Vout                                  | MYBSP0124CAZFT   |                   | 300     | uSec                    |
|                                                                                                                                                                                                                                                                                           |                                                                     | MYBSP01206AZFT   |                   | 400     |                         |
| Dynamic Load Peak Deviation                                                                                                                                                                                                                                                               | same as above                                                       | MYBSP0124CAZFT   |                   | ±100    | mVdc                    |
|                                                                                                                                                                                                                                                                                           |                                                                     | MYBSP01206AZFT   |                   | ±150    |                         |

## FUNCTIONAL SPECIFICATIONS, MYBSP0124CAZFT(CONT.)

| OUTPUT                                                  | Conditions                                         | Minimum        | Typical / Nominal | Maximum | Units          |
|---------------------------------------------------------|----------------------------------------------------|----------------|-------------------|---------|----------------|
| Total Output Power                                      | MYBSP0124CAZFT                                     | 0              |                   | 51      | W              |
|                                                         | MYBSP01206AZFT                                     | 0              |                   | 72      |                |
| <b>Voltage</b>                                          |                                                    |                |                   |         |                |
| Nominal Output Voltage                                  | all conditions                                     | 11.64          | 12                | 12.36   | Vdc            |
| Overvoltage Protection                                  |                                                    | 14.4           |                   |         | Vdc            |
| <b>Current</b>                                          |                                                    |                |                   |         |                |
| Output Current Range *2                                 | MYBSP0124CAZFT                                     | 0              |                   | 4.25    | A              |
|                                                         | MYBSP01206AZFT                                     | 0              |                   | 6       |                |
| Current Limit Inception                                 | MYBSP0124CAZFT                                     | 4.38           |                   |         | A              |
|                                                         | MYBSP01206AZFT                                     | 6.18           |                   |         |                |
| Protection method                                       | Hiccup current limiting                            |                | Non-latching      |         |                |
| <b>Regulation</b>                                       |                                                    |                |                   |         |                |
| Line Regulation                                         | Vin=min. to max., Vout=nom., full load             |                | ±0.1              |         | % of Vout      |
| Load Regulation                                         | Iout = min. to max.                                |                | ±0.1              |         | % of Vout      |
| Ripple and Noise                                        | 150 MHz BW, Cout=10uF MLCC paralleled with 0.1uF   |                | 100               |         | mV pk-pk       |
| Temperature Coefficient                                 | At all outputs                                     |                | ±0.02             |         | % of Vout/degC |
| Maximum Capacitive Loading                              | Low ESR                                            | MYBSP0124CAZFT | 0                 | 100     | uF             |
|                                                         |                                                    | MYBSP01206AZFT | 0                 | 200     |                |
| <b>BT / TPL / TPH / VC / DEN</b>                        |                                                    |                |                   |         |                |
| <b>BT / TPL / TPH</b>                                   |                                                    |                |                   |         |                |
| Sinking Current                                         | After classification, BT / TPL / TPH connect to VC |                | 1.7               |         | mA             |
| <b>VC</b>                                               |                                                    |                |                   |         |                |
| Output Voltage                                          | After start up                                     |                | 11                | 12.36   | V              |
| <b>DEN</b>                                              |                                                    |                |                   |         |                |
| Output Voltage                                          | DEN=open                                           |                |                   | +Vin    | V              |
| Output Current                                          | DEN connect to -Vin                                |                |                   | 5       | mA             |
| Disable Voltage                                         | Falling                                            |                |                   | 2.8     | V              |
| <b>MECHANICAL</b>                                       |                                                    |                |                   |         |                |
| Outline Dimensions                                      | L x W x H                                          |                | 22.2 x 56.4 x 8.6 |         | mm             |
| Weight                                                  |                                                    |                | 21                |         | Grams          |
| Pin Diameter                                            |                                                    |                | 1.02 & 1.57       |         | mm             |
| Pin Material                                            |                                                    |                | Copper alloy      |         |                |
| <b>ENVIRONMENTAL</b>                                    |                                                    |                |                   |         |                |
| Operating Ambient Temperature Range                     |                                                    | -40            |                   | 85      | degC           |
| Thermal Protection/Shutdown                             | Measured at hotspot                                |                | 135               |         | degC           |
| Electromagnetic Interference Conducted, EN55032/CISPR32 | External filter is required                        |                | A                 |         | Class          |
| Electromagnetic Interference Radiated, EN55032/CISPR32  | External filter is required                        |                | B                 |         | Class          |

## Specification Notes

Unless otherwise noted, all specifications are typical at nominal input voltage, nominal output voltage and full load. General conditions are +25degC ambient temperature, near sea level altitude, natural convection airflow. All models are tested and specified with external parallel 10uF and 0.1uF output capacitors (See Technical Notes).

\*1 Input current overcurrent protection limits output power at low input voltage.  
Refer to the following graph for input voltage vs. output power.

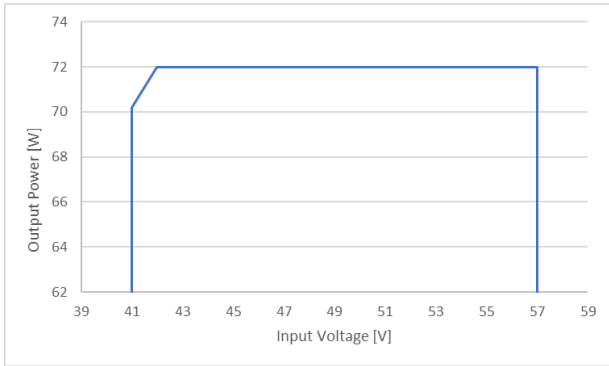

\*2 Input current must be greater than or equal to 16mA if your application applies Maintain Power Signature(MPS) by IEEE802.3bt. Please check with your application.

PERFORMANCE DATA, MYBSP0124CAZFT

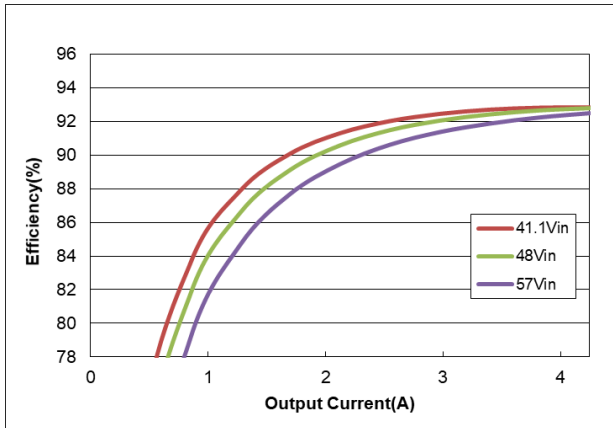

(Ta=25degC)

**Figure 3. Efficiency vs. Line Voltage and Load Current**

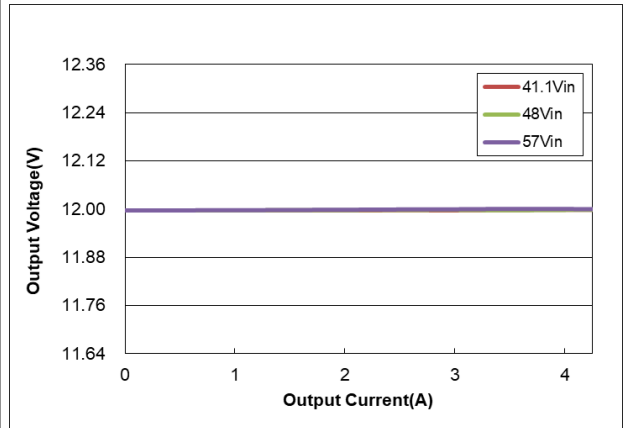

(Ta=25degC)

**Figure 4. Load Regulation**

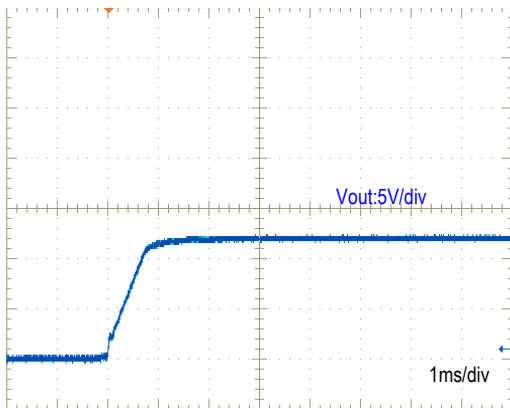

(Vin=48V, Iout=4.25A, Ta=25degC)

**Figure 5. Vout Start-up**

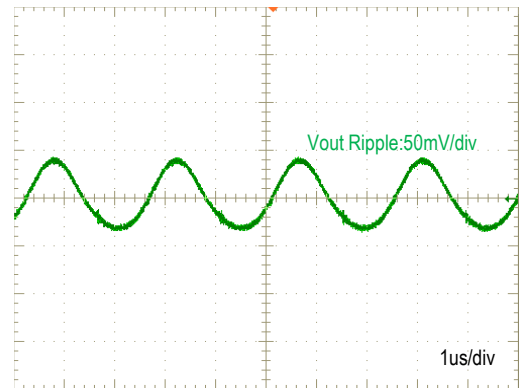

(Vin=48V, Iout=4.25A, Ta=25degC)

**Figure 6. Output Ripple and Noise**

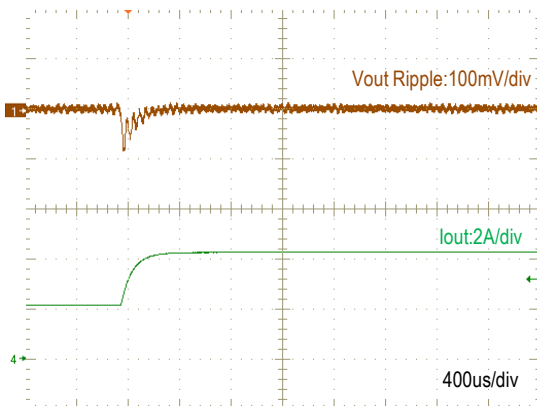

(Vin=48V, Iout=2.13A to 4.25A, Ta=25degC)

**Figure 7. Transient Response**

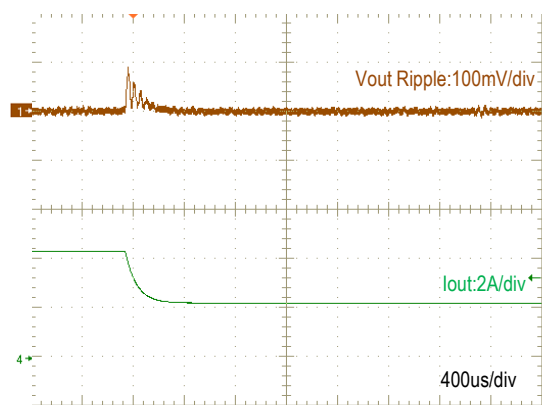

(Vin=48V, Iout=4.25A to 2.13A, Ta=25degC)

**Figure 8. Transient Response**

PERFORMANCE DATA, MYBSP0124CAZFT(CONT.)

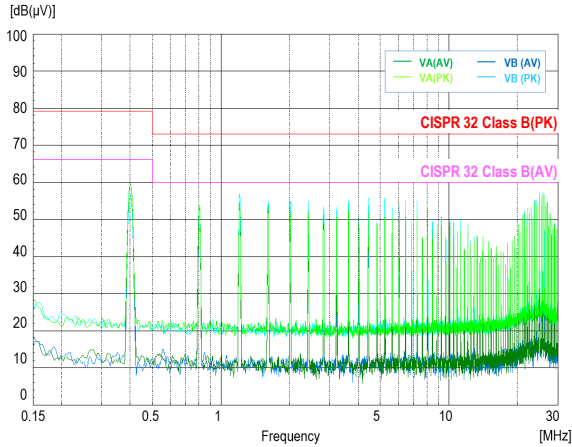

(Vin=48V, Iout=4.25A, Ta=25degC) with External Input Filter  
**Figure 9. Conduction Noise**

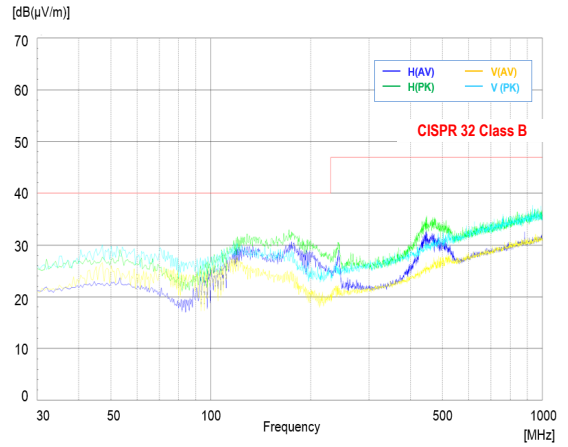

(Vin=48V, Iout=4.25A, Ta=25degC) with External Input Filter  
**Figure 10. Radiation Noise**

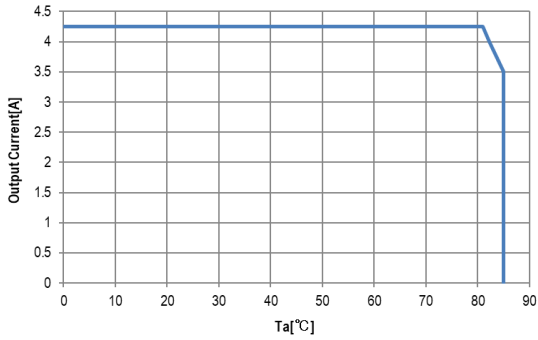

Unit under test (UUT) is covered by acrylic box to avoid airflow.  
(Vin=48V, See [Technical Notes](#))  
**Figure 11. Thermal Derating**

PERFORMANCE DATA, MYBSP01206AZFT

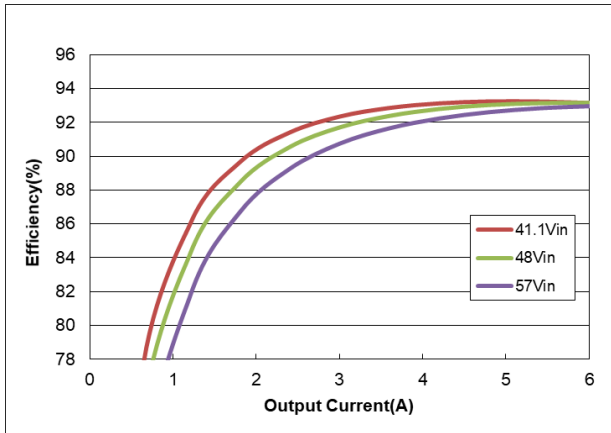

(Ta=25degC)

**Figure 12. Efficiency vs. Line Voltage and Load Current**

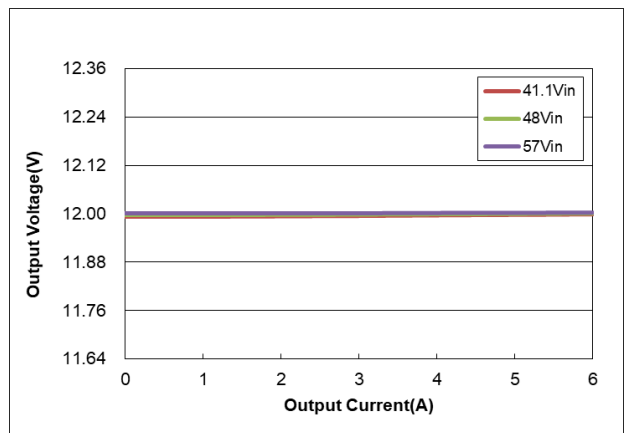

(Ta=25degC)

**Figure 13. Load Regulation**

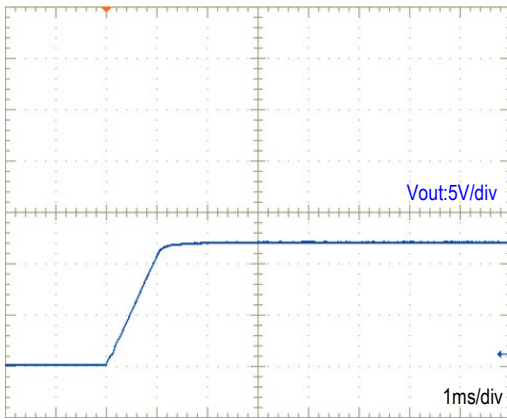

(Vin=48V, Iout=6A, Ta=25degC)

**Figure 14. Vout Start-up**

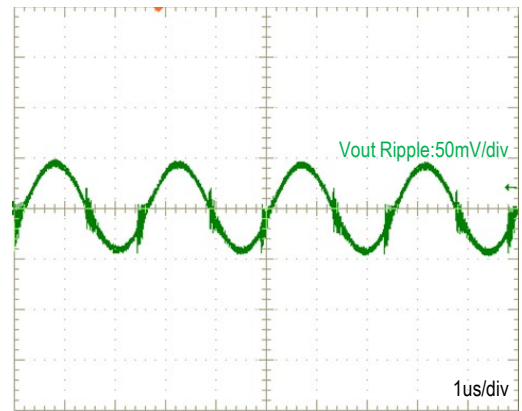

(Vin=48V, Iout=6A, Ta=25degC)

**Figure 15. Output Ripple and Noise**

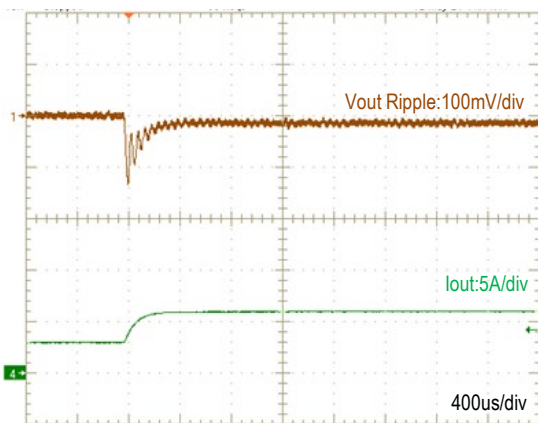

(Vin=48V, Iout=3A to 6A, Ta=25degC)

**Figure 16. Transient Response**

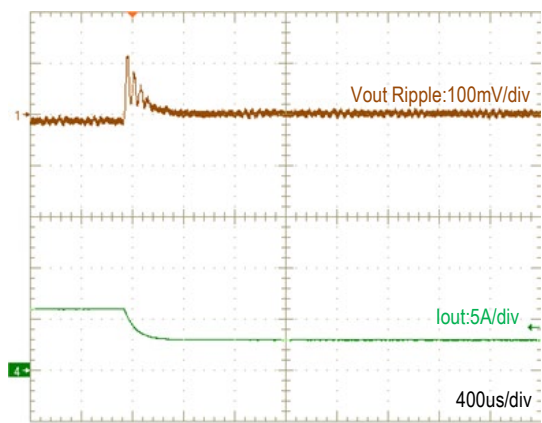

(Vin=48V, Iout=6A to 3A, Ta=25degC)

**Figure 17. Transient Response**

PERFORMANCE DATA, MYBSP01206AZFT(CONT.)

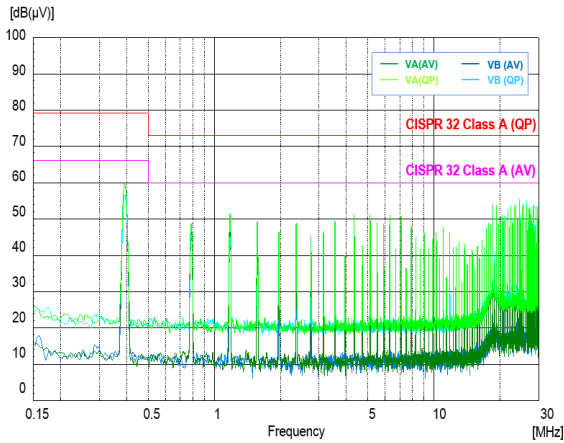

(Vin=48V, Iout=6A, Ta=25degC) with External Input Filter  
**Figure 18. Conduction Noise**

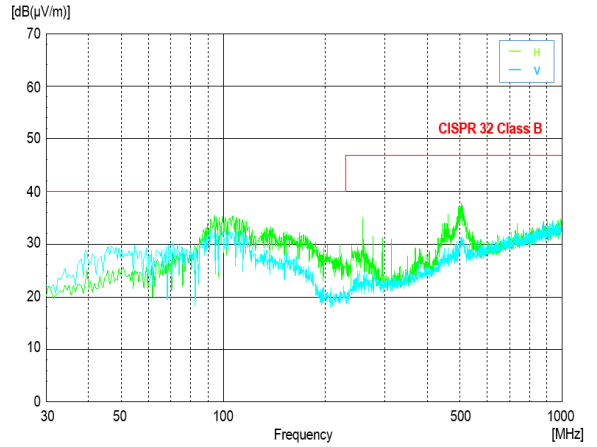

(Vin=48V, Iout=6A, Ta=25degC) with External Input Filter  
**Figure 19. Radiation Noise**

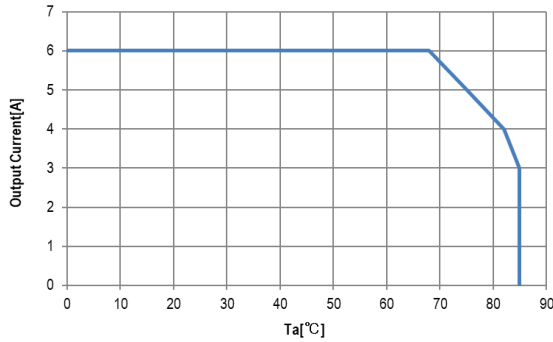

Unit under test (UUT) is covered by acrylic box to avoid airflow.  
(Vin=48V, See [Technical Notes](#))

**Figure 20. Thermal Derating**

MECHANICAL SPECIFICATIONS

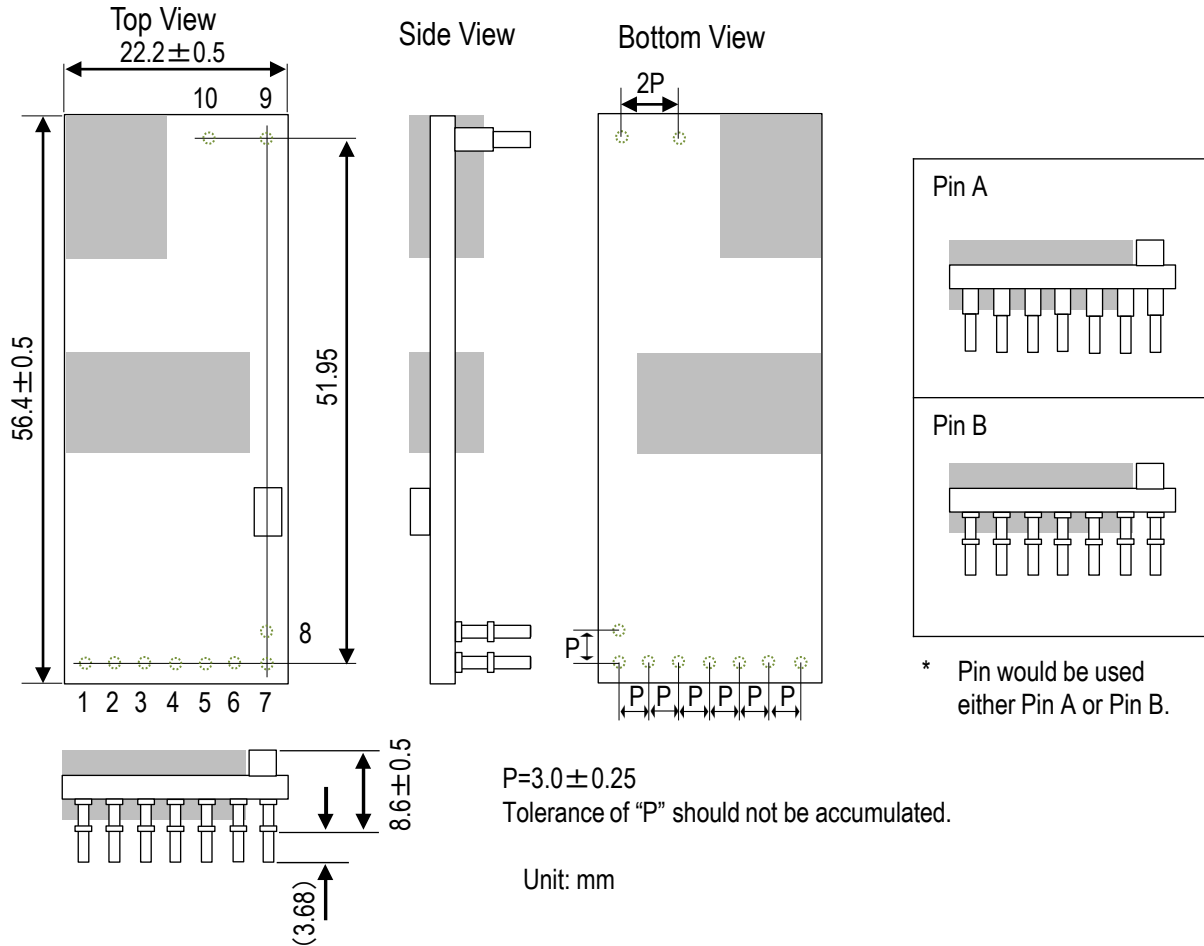

Figure 21. Product Dimensions

■ Pin Assignment

Table 4. Pin Function & Descriptions

| INPUT / OUTPUT CONNECTIONS |             |                          |          |                   |
|----------------------------|-------------|--------------------------|----------|-------------------|
| Pin                        | Designation | Function                 | Pin size | Pin shoulder size |
| 1                          | +Vin        | Positive Input Voltage   | Φ1.02    | Φ1.57             |
| 2                          | RTN         | External Input Capacitor | Φ1.02    | Φ1.57             |
| 3                          | VC          | Controller Voltage       | Φ1.02    | Φ1.57             |
| 4                          | BT          | PSE Type Indicator       | Φ1.02    | Φ1.57             |
| 5                          | TPL         | PSE Type Indicator       | Φ1.02    | Φ1.57             |
| 6                          | TPH         | PSE Type Indicator       | Φ1.02    | Φ1.57             |
| 7                          | -Vin        | Negative Input Voltage   | Φ1.02    | Φ1.57             |
| 8                          | DEN         | Detection and Enable     | Φ1.02    | Φ1.57             |
| 9                          | -Vout       | Negative Output Voltage  | Φ1.57    | Φ2.36             |
| 10                         | +Vout       | Positive Output Voltage  | Φ1.57    | Φ2.36             |

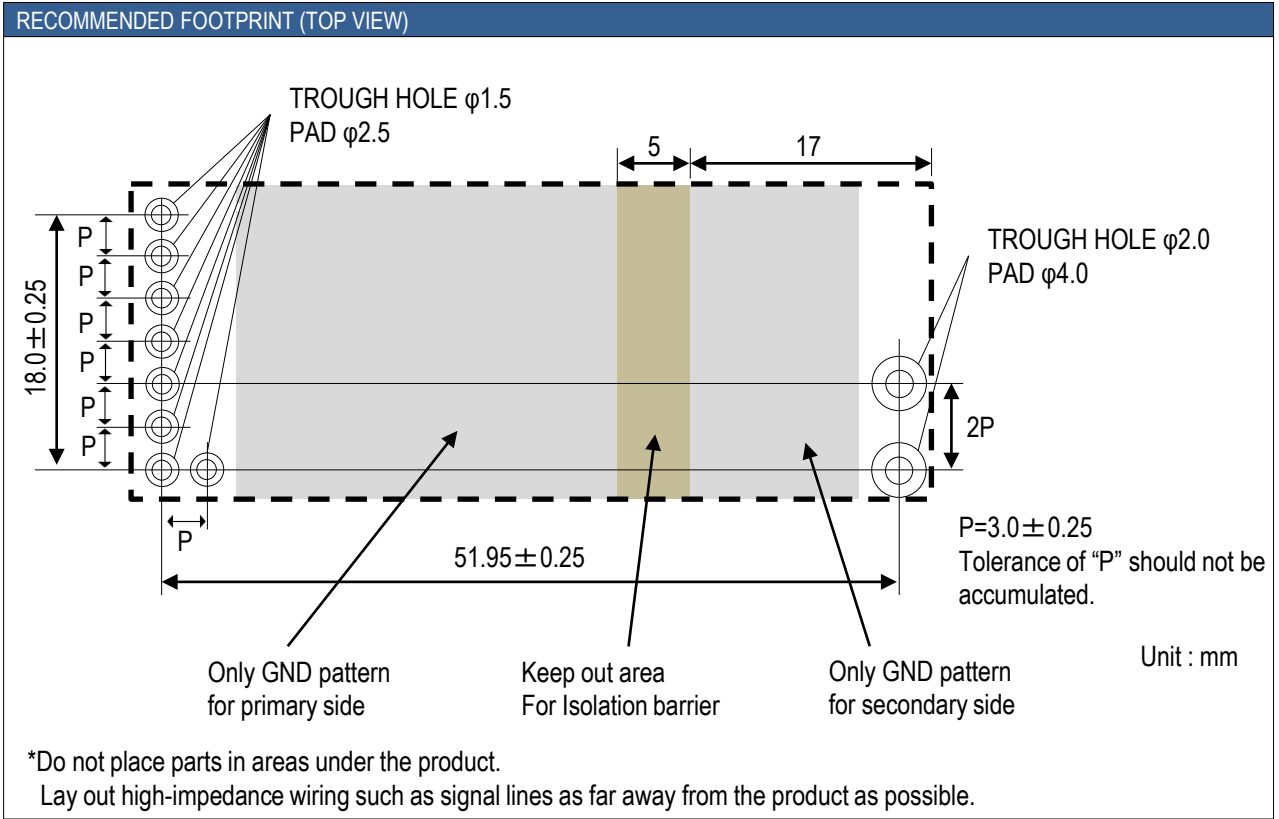
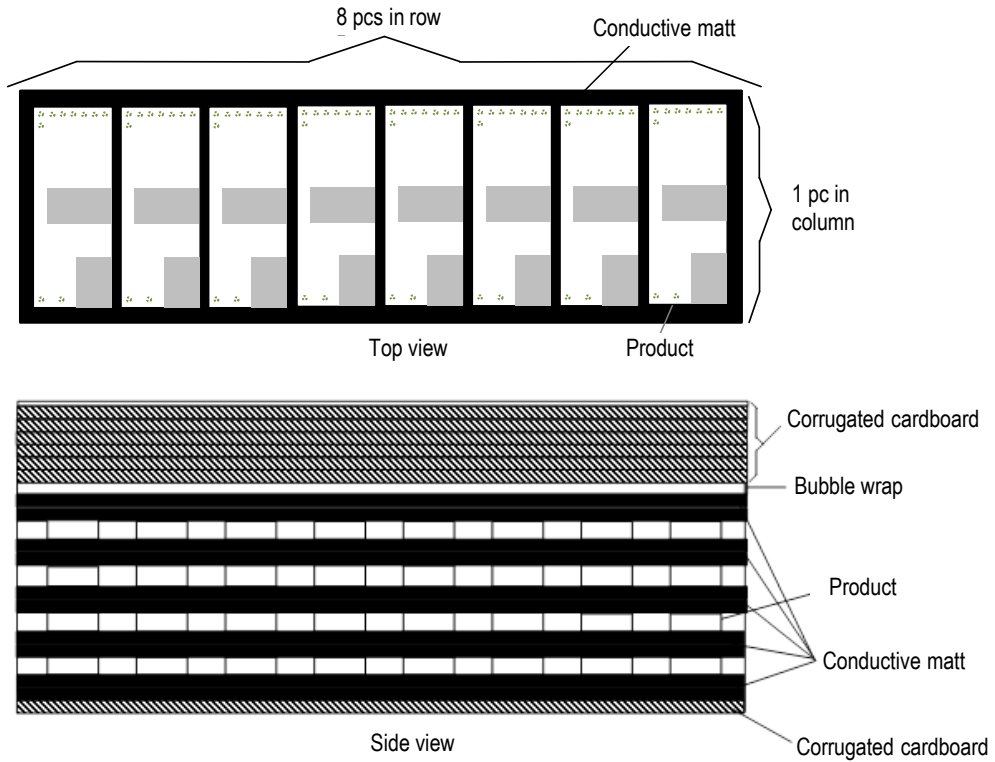

Figure 22. Recommended Footprint

**PACKAGING INFORMATION**

Packaging form (Carton box)

1. The products are placed in the conductive mat (1 row × 8 column) as below
2. Pile these conductive mats and pack maximum 4 units in carton box.

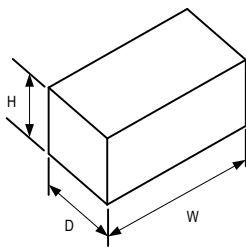
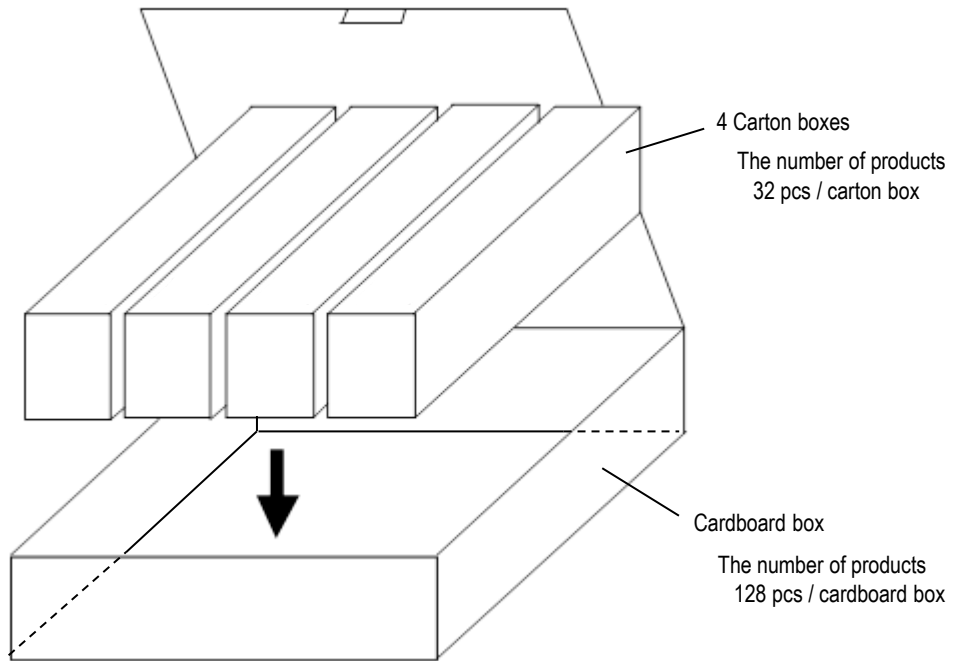

**Figure 23. Packaging Form (Carton box)**

| Item                                                                                                                | Specification                                                    | Remark<br>• The number of contained products may not reach to the maximum number. |
|---------------------------------------------------------------------------------------------------------------------|------------------------------------------------------------------|-----------------------------------------------------------------------------------|
| Packaging form typical classification                                                                               | Box                                                              |                                                                                   |
| Dimensions of packaging form<br> | <p>W = 245 ( mm )</p> <p>D = 78 ( mm )</p> <p>H = 104 ( mm )</p> |                                                                                   |
| The number of products in a packaging form                                                                          | 32 (pcs.)                                                        |                                                                                   |

PACKAGING INFORMATION(CONT.)

Packaging form (Cardboard box)  
4 carton boxes per cardboard box.



**Figure 24. Packaging Form (Cardboard box)**

### TECHNICAL NOTES

#### Over Current Protection

Over Current Protection operates with a controller circuit failure or over-load condition, and DC-DC converter will enter hiccup mode. After rejected the abnormal mode, DC-DC converter will automatically restart.

#### Over Voltage Protection

Output halts in hiccup mode while Output Voltage is over the value of OVP specified with failure of controller circuit. DC-DC converter will enter a hiccup mode. After rejected the abnormal mode, DC-DC converter will automatically restart.

#### Over Temperature Protection

When DC-DC converter is heated abnormally, it will shut down. After it is cooled down, DC-DC converter will automatically restart.

#### External Input Capacitor

An external input capacitor can be added between positive input (+ Vin) and RTN to stabilize the operation of the DCDC converter. When EMI Suppression Filters are added, additional capacitors may be needed to stabilize the operation. The withstand voltage for the input voltage is required.

But do not connect any capacitor between positive input(+Vin) and negative input(-Vin) to avoid large inrush current. It is one of the requirements of IEEE802.3bt standard.

#### Test Circuit

The initial values in Functional Specification are measured in the following test circuit.

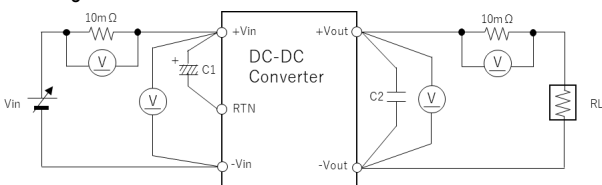

C1 : Low Impedance Electrolytic Capacitor : None

C2 : Ceramic Capacitor : 10uF+0.1uF

RL : Electronic Load Device : LN-1000A-G7 KEISOKU GIKEN equivalent

Vin : DC Power Supply :Model HP6675A KEYSIGHT equivalent

Ⓜ : Digital Multimeter :Model HP34401A KEYSIGHT equivalent

When deviating from the above, DC-DC converter may operate abnormally. It should be fully confirmed on your board before use.

#### Ripple Noise Test

Output ripple noise is measured using designated external output components, circuits and layout as shown below.

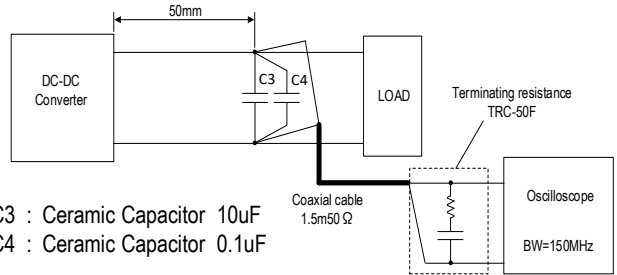

C3 : Ceramic Capacitor 10uF

C4 : Ceramic Capacitor 0.1uF

#### EMI Test

The external input filter is installed and the circuit diagram is shown below.

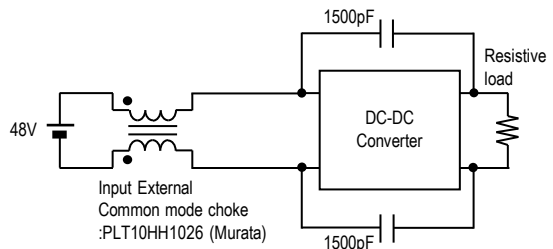

(A) MYBSP0124CAZFT

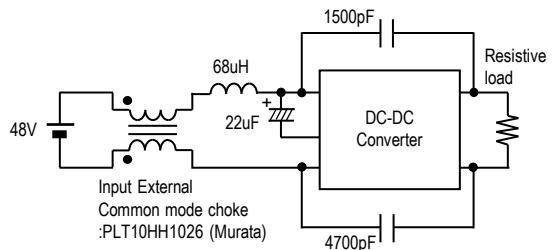

(B) MYBSP01206AZFT

### PSE Type Indicator

BT, TPL and TPH (Pin4~6) is open drain output. After classification with PSE Type 3-4, MYBSP0124CAZFT pulls BT and TPH Pins indicator low. After classification with PSE Type 4, MYBSP01206AZFT pulls 3 Pins indicator low. Please pull up BT, TPL and TPH by VC (Pin3). VC is source only for this function. Do not apply VC for any other purpose. Appropriate board design for isolation barrier is required (Opto-coupler selection and Isolation distance). Also consider CTR of Opto-coupler which may affect value of R1~R3. Keep BT, TPL, TPH and VC open if you don't apply this function. Typical application circuit is below.

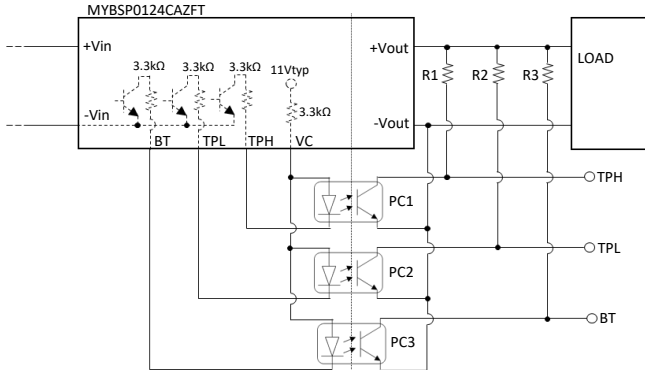

Example  
R1, R2, R3 : 15kΩ 0.1W  
PC1, PC2, PC3 : TLP293(GRH) (TOSHIBA)

| PSE Type | PD Class | Number of CLASS Cycles | TPH | TPL  | BT  |
|----------|----------|------------------------|-----|------|-----|
| 3-4      | 5-6      | 4                      | LOW | HIGH | LOW |

(A) MYBSP0124CAZFT

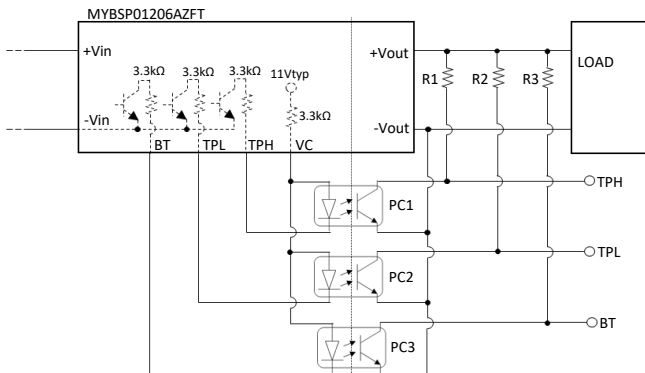

Example  
R1, R2, R3 : 15kΩ 0.1W  
PC1, PC2, PC3 : TLP293(GRH) (TOSHIBA)

| PSE Type | PD Class | Number of CLASS Cycles | TPH  | TPL  | BT   |
|----------|----------|------------------------|------|------|------|
| 1-2      | 0-3      | 1                      | HIGH | HIGH | HIGH |
| 2        | 4        | 2                      | HIGH | LOW  | HIGH |
| 3-4      | 0-3      | 1                      | HIGH | HIGH | LOW  |
| 3-4      | 4        | 2-3                    | HIGH | LOW  | LOW  |
| 3-4      | 5-6      | 4                      | LOW  | HIGH | LOW  |
| 4        | 7-8      | 5                      | LOW  | LOW  | LOW  |

(B) MYBSP01206AZFT

### Adapter ORing

DEN (Pin8) handles Enable / Disable of MYBSP0124CAZFT and MYBSP01206AZFT. In case of applying external power output by adapter, MYBSP needs to be disable. Connecting DEN to -Vin disable MYBSP. There is limitation for voltage from adapter. Keep open if you don't use this function. Typical application circuit is below.

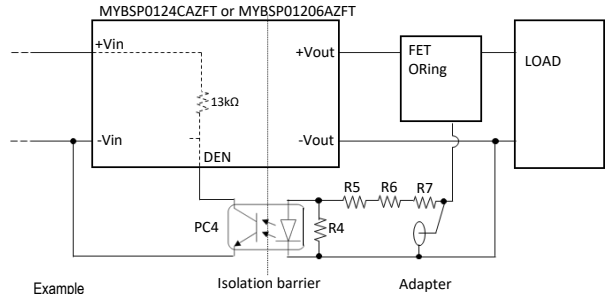

Example  
R4 : 3.3kΩ 0.1W  
R5, R6, R7 : 330Ω 0.25W  
PC4 : TLP293(GRH) (TOSHIBA)

### Limitation for adapter voltage

| P/N            | Acceptable voltage range from Adapter at Vout |
|----------------|-----------------------------------------------|
| MYBSP0124CAZFT | 10.8 – 12.8V                                  |
| MYBSP01206AZFT |                                               |

### Thermal Derating Condition

The output current is limited by the derating curve. The derating curve in this datasheet illustrate typical operation under a variety of conditions.

DC-DC Converter is tested on a 101.6x188mm, 2 layers Copper evaluation board at Vin=48V.

The Unit Under Test (UUT) is set up as shown below.

UUT is covered by acrylic box to avoid airflow.

The temperature measurement points are shown below table. The temperature of measurement points should not exceed the maximum temperatures in the below table.

| Position | Description         | Max temperature              |
|----------|---------------------|------------------------------|
| P1       | FET                 | T <sub>P1MAX</sub> = 124degC |
| P2       | FET                 | T <sub>P2MAX</sub> = 124degC |
| P3       | Opto-coupler        | T <sub>P3MAX</sub> = 105degC |
| P4       | Transformer pattern | T <sub>P4MAX</sub> = 125degC |
| P5       | Transformer pattern | T <sub>P5MAX</sub> = 125degC |
| P6       | Snubber             | T <sub>P6MAX</sub> = 125degC |

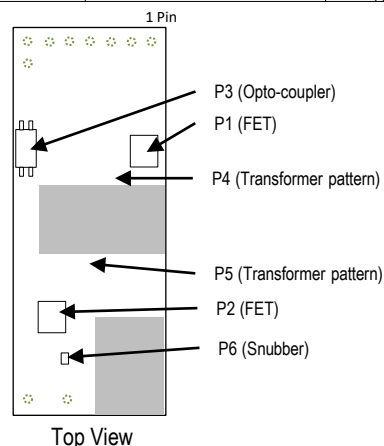

Top View

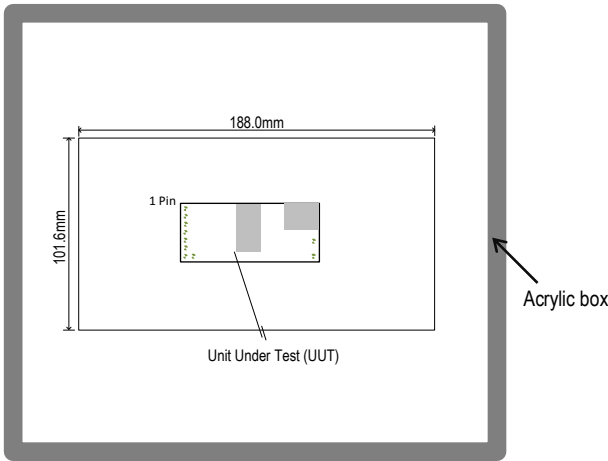

**Through Hole Soldering Guidelines**

Murata recommends the specifications below when installing these converters. These specifications vary depending on the solder type. Exceeding these specifications may cause damage to the product. Your production environment may differ; therefore please thoroughly review these guidelines with your process engineers.

Flux : Rosin Flux which contains chlorine 0.2wt% or less.  
Do not use high activity acid flux and water soluble flux.

Solder : Use the solder Sn-3Ag-0.5Cu or the equivalent type.

**Condition of Flow Soldering**

- Preheat : 120 ± 10 degC / 60 to 120 seconds
- Soldering temperature : 260 degC +0/-5 degC
- Soldering time : 10 seconds max.

**Condition of Iron Soldering**

- Preheat : 120 ± 10 degC / 30 minutes max.
- Soldering temperature : 350 degC max.
- Soldering time : 3 seconds max.

**Detection and Hardware Classification**

DC-DC converter implements IEEE 802.3bt compliant detection and hardware classification.

When DC-DC converter(PD) is connected to PSE, the PSE applies two voltages in the range of 2.7 V to 10.1 V and measures the corresponding current. Connection to PD is detected by measured current.(Detection)

After Detection, the PSE applies voltage in the range of 14.5 V to 20.5 V and measures the corresponding current. PD is classified by measured current.(Hardware Classification)

Please check with your application.

**Power Demotion**

Power Demotion allows the PSE to supply power to a PD even if the PSE does not have all of the PD's requested power available. Also it allows higher power PDs to operate in a reduced mode when connected to lower power PSEs.

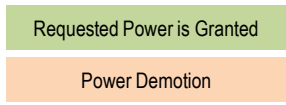

| Power Demotion |                     |                             |                           |                           |                           |                           |
|----------------|---------------------|-----------------------------|---------------------------|---------------------------|---------------------------|---------------------------|
| Type Power     | PSE Power Available | PD(25.5W) Class 4 Requested | PD(40W) Class 5 Requested | PD(51W) Class 6 Requested | PD(62W) Class 7 Requested | PD(71W) Class 8 Requested |
| Type 1         | 15W                 | 12.9W                       | 12.9W                     | 12.9W                     | 12.9W                     | 12.9W                     |
| Type 2         | 30W                 | 25.5W                       | 25.5W                     | 25.5W                     | 25.5W                     | 25.5W                     |
| Type 3         | 45W                 | 25.5W                       | 40W                       | 25.5W                     | 25.5W                     | 25.5W                     |
|                | 60W                 | 25.5W                       | 40W                       | 51W                       | 51W                       | 51W                       |
| Type 4         | 75W                 | 25.5W                       | 40W                       | 51W                       | 62W                       | 51W                       |

### Scope

This datasheet is applied to MYBSP0124CAZFT and MYBSP01206AZFT.

- Specific applications: Consumer Electronics, Industrial Equipment

### Limitation of Applications

The products listed in the datasheet (hereinafter the product(s) is called the "Product(s)") are designed and manufactured for applications specified in the specification or the datasheet. (hereinafter called the "Specific Application"). We shall not warrant anything in connection with the Products including fitness, performance, adequateness, safety, or quality, in the case of applications listed in from (1) to (11) written at the end of this precautions, which may generally require high performance, function, quality, management of production or safety. Therefore, the Product shall be applied in compliance with the specific application.

We disclaim any loss and damages arising from or in connection with the products including but not limited to the case such loss and damages caused by the unexpected accident, in event that (i) the product is applied for the purpose which is not specified as the specific application for the product, and/or (ii) the product is applied for any following application purposes from (1) to (11) (except that such application purpose is unambiguously specified as specific application for the product in our catalog specification forms, datasheets, or other documents officially issued by us\*).

- (1) Aircraft equipment
- (2) Aerospace equipment
- (3) Undersea equipment
- (4) Power plant control equipment
- (5) Medical equipment
- (6) Transportation equipment (such as vehicles, trains, ships)
- (7) Traffic control equipment
- (8) Disaster prevention / crime prevention equipment
- (9) Industrial data-processing equipment
- (10) Combustion/explosion control equipment
- (11) Application of similar complexity and/or reliability requirements to the applications listed in the above

For exploring information of the Products which will be compatible with the particular purpose other than those specified in the datasheet, please contact our sales offices, distribution agents, or trading companies with which you make a deal, or via our web contact form.

Contact form: <https://www.murata.com/contactform>

\*We may design and manufacture particular Products for applications listed in (1) to (11). Provided that, in such case we shall unambiguously specify such Specific Application in specification or datasheet without any exception. Therefore, any other documents and/or performances, whether exist or non-exist, shall not be deemed as the evidence to imply that we accept the applications listed in (1) to (11).

### Fail-safe function

Be sure to add an appropriate fail-safe function to your finished product to prevent secondary damage in the unlikely event of an abnormality function or malfunction in our product.

Please connect the input terminal by right polarity. If you mistake the connection, it may break the DC-DC converter. In the case of destruction of the DC-DC converter inside, over input current may flow. Please add a diode and fuse as following to protect them.

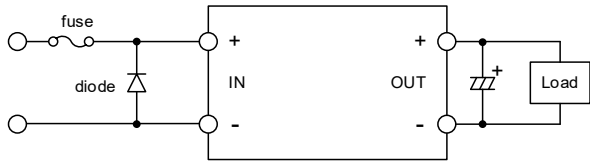

Please select diode and fuse after confirming the operation.

### ⚠ Note

1. Please make sure that your product has been evaluated in view of your specifications with our product being mounted to your product.
2. You are requested not to use our product deviating from the reference specifications.
3. If you have any concerns about materials other than those listed in the RoHS directive, please contact us.
4. Please don't wash this product under any conditions.

### Storage

Please store this product in an environment where the temperature/humidity is stable in the range 0 to 40degC/10 to 75%RH and no direct sunlight. Use the product within 6 months after delivery.

Please avoid storage conditions where humidity and temperature change rapidly, as that may cause condensation on the product, which might degrade the quality of the product.

Please do not store the product environments that are dusty, in direct exposure to sea breeze, or in an atmosphere containing corrosive gas (Cl<sub>2</sub>, NH<sub>3</sub>, SO<sub>2</sub>, NO<sub>x</sub> and so on).

### Note Prior to use

If you apply high static electricity, voltage higher than rated voltage or reverse voltage to the product, it may cause defects in the products or degrade the reliability.

Please avoid the following items:

1. Over rating power supply, reverse power supply or not-enough connection of input voltage and 0V(DC)line
2. Electrostatic discharge by production line and/or operator
3. Electrified product by electrostatic induction

Do not subject product to excessive mechanical shock. If you drop the product on the floor it might cause a crack to the core of inductors and monolithic ceramic capacitors.

Also please pay attention to handling; the mounted parts can be dislodged if subjected to excessive force.

### Operational environment and operational conditions

This product is not chemical-proof or rust-proof.

In order to prevent this product from leakage of electricity and/or abnormal temperature increase, do not use the product under the following circumstances:

- (1) in an atmosphere containing corrosive gas (Cl<sub>2</sub>, NH<sub>3</sub>, SO<sub>2</sub>, NO<sub>x</sub> and so on).
- (2) in a dusty place.
- (3) in a place exposed to direct sunlight.
- (4) in such a place where water splashes or in such a humid place where water condenses.
- (5) in a place exposed to sea breeze.
- (6) in any other places similar to the above (1)through (5).

#### Operational Conditions

Please use the product within specified values (power supply, temperature, input, output and load condition etc.). Input voltage drops for line impedance, so please make sure that input voltage is within in specified values.

If the product is used over the specified values, it may damage the product, reduce the quality, and even if the products can endure the condition for short time, it may cause degradation of the reliability.

### Transportation

If you transport the product, please pack it so that the package will not be damaged by mechanical vibration or mechanical shock, and please educate and guide the carrier to prevent rough handling.

### Product Specification

Product Specification in this datasheet are as of February 2024. Specifications and features may change in any manner without notice. Please check with our sales representatives or product engineers.

### Disclaimers

The information described in this data sheet was carefully crafted for accuracy. However this product is based on the assumption that it will be used after thoroughly verifying and confirming the characteristics and system compatibility. Therefore, Murata is not responsible for any damages caused by errors in the description of the datasheet.

Murata constantly strives improve the quality and reliability of our products, but it is inevitable that semiconductor products will fail with a certain probability. Therefore regardless of whether the use conditions are within the range of this data sheet, Murata is not responsible for any damage caused by the failure of this product, (for example, secondary damage, compensation for accidents, punitive damage, loss of opportunity, and etc.) Also, regardless of whether Murata can foresee the events caused by the failure of our product, Murata has no obligations or responsibilities.

The buyer of this product and developer of systems incorporating this product must analyze, evaluate, and make judgements at their own risk in designing applications using this product. The buyer and the developer are responsible for verifying the safety of this product and the applications, and complying with all applicable laws, regulations, and other requirements.

Furthermore, the buyer and developer are responsible for predicting hazards and taking adequate safeguards against potential events at your own risk in order to prevent personal accidents, fire accidents, or other social damage. When using this product, perform thorough evaluation and verification of the safety design designed at your own risk for this product and the application.

Murata assumes that the buyer and developer have the expertise to verify all necessary issues for proper use of the product as described above and to take corrective action. Therefore, Murata has no liability arising out of the use of the product. The buyer and developer should take all necessary evaluations, verifications, corrective actions and etc., in your own responsibility and judgment.

This data sheet does not guarantee or grant any license to the information, including patents, copyrights, and other intellectual property rights, of the Murata or third parties. Regardless of whether the information described in this datasheet is express or implied, Murata does not take any responsibility or liability for any claims, damages, costs, losses, etc. relating to intellectual property rights or other rights from third parties due to the use of these information.

## Contact form

<https://www.murata.com/contactform?Product=Power%20Device>

## Patent Statement

Murata products are protected to under one or more of the U.S. patents.

## Copyright and Trademark

©2024 Murata Manufacturing Co., Ltd. All rights reserved.



This product is subject to the following [operating requirements](#) and the [Life and Safety Critical Application Sales Policy](#):

Refer to: <https://power.murata.com/en/requirements>

Murata Manufacturing Co., Ltd makes no representation that the use of its products in the circuits described herein, or the use of other technical information contained herein, will not infringe upon existing or future patent rights. The descriptions contained herein do not imply the granting of licenses to make, use, or sell equipment constructed in accordance therewith. Spec and cautions are subject to change without notice.